



## Board of Editors

### Chief Editor

**Dr. capt. Hesham Helal**  
President of AIN

### Members

**Prof. Krzysztof Czaplewski**  
President of Polish Navigation Forum,  
Poland

**H.E. Dr. Yousry El Gamal**  
Former Minister of Education, Egypt

**Dr. Ahmed El Rabbany**  
Graduate Program Director, Ryerson  
University, Canada.

**Dr. Mohamed El Fayoumi**  
Faculty of Commerce, Alexandria  
University, Egypt

**Capt. Mohamed Youssef Taha**  
Arab Institute of Navigation

**R. Adm. (Rt.) Dr. Sameeh  
Ibrahim**  
Arab Institute of Navigation

**Dr. Refaat rashad**  
Arab Institute of Navigation

**Dr. M. Abdel El Salam Dawood**  
Vice President for Maritime Affairs,  
AASMT, Egypt

**Ms/ Esraa Ragab Shaaban**  
Journal Coordinator

**Ms/ Mennatallah Mohamed  
Soliman**  
Journal Coordinator

### **Arab Institute of Navigation**

Cross Road of Sebaci Street & 45  
St., Miami, Alexandria, Egypt

**Tel:** (+203) 5509824

**Cell:** (+2) 01001610185

**Fax:** (+203) 5509686

**E-mail:** ain@aast.edu

**Website:** www.ainegypt.org

## Journal of The Arab Institute of Navigation

Semi Annual Scientific Journal

Issue 44 (volume 2) July 2022

ISSN (2090-8202)

INDEXED IN (EBSCO)

### Contents

#### Editorial

#### English Papers

#### **Numerical Modeling for Tidal Characteristics and Datum Calculation from Sea Level Simulation in Al-Ahmadi Harbor, Kuwait**

Dr. Ahmed M. Khedr - Dr. Mohamed Mohsen -  
Dr. Mostafa Rabah – Dr. Fahmy Abd Elhaleem

#### **Green Port Performance Assessment In the Egypt Context**

Dr. Mohamed H. M. Hassan – Dr. Ahmed  
Mohamed Aly

#### **Tidal Datum Levels Realization based on observed Sea level data analysis in Port Said, Egypt**

Dr. Ahmed M Khedr - Ms. Nada M Salama -  
Mr. Mohamed M Helmy - Dr. Hassan A ELHalawany

#### **Foundational Concepts and Application Challenges of the GMP-BoK in light of Seafaring Officers' Perspectives**

Dr. Hossam Eldin Gadalla – Dr. Ahmed Ismail – Dr.  
Ibrahim Tayel

#### **Effect of Occupancy on Air Outlet Design Alternatives in Ship's Crew Cabins**

Dr. Khaled Senary – Dr. Amman Ali

#### **The impact of developing navigational aids on improving navigation safety and evaluated the effectiveness of the navigational aids along the Egyptian coast from Alexandria to Damietta**

Capt. Mohamed Shendy, Capt. Samy Youssef

#### **Effect of the Suez Canal on Marine Invasive Species Entry to the Mediterranean and Methods of Mitigation.**

DR. Mamdouh Awad Abdelrahman Shahhat

#### Arabic Papers

#### **Confronting the Open Ship Registration System and Substandard Ships by Port State Control**

Cap\ Nael Mohamed ElKhaldy

#### **Requirements for the use of application enterprise resource planning systems (ERP) in order to develop seaports- Tripoli sea port**

Dr. Amohamed Saad Amohamed Masoud  
Dr. Nermeen Khalifa – Dr. Eman Hadad - Dr.  
Mohamed el saadamy

#### **The effective role of supervisory and classification bodies in the application of maritime safety standards on board commercial ships**

Cap\ Nael Mohamed ElKhaldy

## **The Russia-Ukraine war affect on the shipping Industry**

No doubt, 2020 was a pivotal point for many industries, and the shipping sector was no exception. And just when the conditions were starting to return to their right track, the world witnessed a war that shocked the global economy. The first ripple was the smallest, and as time passes, it gets bigger and its effect widens. As a result of the Russian invasion that started at the end of February this year, Russia is subjected to a variety of economic penalties and sanctions that have been targeted at various sectors. All Russian ships have been barred from entering British ports, while other Western European countries, such as Germany, Belgium, and the Netherlands, may use comparable detentions in the meantime. Sanctions on shipping businesses could include the freezing of bank accounts, assets, financial fines, and the halt or detention of cargo and ships.

Maersk, one of the world's largest shipping container companies and having had a presence in Russia since 1992, stated their concerns on their website. "Our preparations include the possibility of suspending Maersk bookings to and from Russia, both on the ocean and inland," the company said in a statement. The International Monetary Fund has warned that the crisis in Ukraine could worsen already high shipping costs this year, perhaps keeping them higher – and their inflationary implications – for longer. In the 18 months following March 2020, the cost of shipping a container on transoceanic trade routes soared sevenfold, while the cost of carrying bulk commodities increased even more.

But the most important factor is, as always, the human factor, which is represented in the shipping industry by the seafarers. According to the IMO, at the start of the conflict, approximately 2,000 seafarers were stranded aboard 94 vessels in Ukrainian ports. As of April 20, 2022, 84 merchant ships with nearly 500 seafarers on board remained. An estimated 1,500 seafarers have been repatriated so far, with manning levels reduced, local ship keepers hired to replace crew, and some ships in cold lay-up with no crew on board. For those who remain, the IMO has called for the immediate establishment of a blue-safe maritime corridor to allow the evacuation of seafarers and ships from high-risk and affected areas in the Black Sea and the Sea of Azov. However, it is unclear whether vessels will be able to depart safely.

However, not just the fate of those seafarers that's uncertain, speculations of the whole invasion started to emerge. All with the goal to anticipate the possible future scenarios and be prepared for them as much as possible. One is to replace the current Ukrainian government with another that is pro-Russia as to ensure the loyalty of the country. Another option to be prepared for is the continuation of the invasion which will face a massive resistance from the Ukrainians with the help of the EU, USA and other supporting nations. And unlike the first option the resistance will be heavily armed and the casualties will be in a much greater number. A final and optimistic solution is the success of the western sanctions that leads to the retreat of the Russian army. That is still by far the least possible solution for the repercussions that will face the Russian government will be exorbitant and not an easy option to lean to even at the hardest times, for both options, there will be an impact on the shipping industry.

**Editorial Board**

# Numerical Modeling for Tidal Characteristics and Datum Calculation from Sea Level Simulation in Al-Ahmadi Harbor, Kuwait.

Prepared by

Ahmed M.Khedr 1 \*, Mohamed Mohsen 2 , Mostafa Rabah 2  
and Fahmy Abd Elhaleem 2

1. College of Maritime Transport and Technology, Arab  
Academy for Science, Technology and Maritime Transport,

2. Benha University, Faculty of Engineering, Civil  
Engineering Department, Benha, Qalyubia,

Egypt.

## المستخلص:

تعتبر قياسات مستوى سطح البحر أحد أهم المتغيرات في علم المحيطات الفيزيائية، بجانب أهميته في عمليات المساحة البحرية، وذلك لتحديد مستوى اساس الخريطة. يعتبر أقل مستوى مدري فلكي بمثابة السطح الفيزيائي والذي يعد أكثر المستويات الرأسية استخدامًا في الآونة الأخيرة من قبل المنظمة الدولية للمساحة البحرية والتي قامت بتعريفه علي أنه أقل مستوى مدري يمكن أن يصل إليه مستوى سطح البحر تحت تأثير ظروف مناخية متوسطة وتحت التأثير المشترك للقوى المدرية الفلكية. في هذا البحث تم تعديل حساب و تعريف أقل مستوى مدري فلكي على اساس أنه المستوى المدري الرأسي الذي يتم إسناد الاعماق اليه على الخرائط الملاحية البحرية في عمليات المساحة البحرية، ويعد الهدف الرئيسي من هذا البحث هو حساب ارتفاع مستوي الاسناد الملاحي من متوسط منسوب سطح البحر بميناء الأحمدى بالكويت. تم الحصول علي قياسات مستوى سطح البحر عن طريق حساس ضغط المياه المثبت على جهاز قياس التيارات البحرية، والذي تم استخدامه في تمثيل سطح البحر عن طريق برنامج النمذجة العددية الهيدروديناميكية للحصول علي مستوي الاسناد الملاحي. تم رصد كلا البيانات ( المرصودة - الممنذجة عدديا)، ثم تحليلهم بواسطة التحليل التوافقي البسيط لفصل المركبات المدرية عن المركبات غير المدرية وذلك لتحليلها. من نتائج التحليل لكلاً من سطح البحر المقاس و سطح البحر الي تم تمثيله تم حساب معامل الارتباط، ووجد أن هناك معامل ارتباط كبير بين المركبات المدرية من تحليل منسوب سطح البحر لكلا البيانات المرصودة والممثلة بالمنطقة تصل إلى 97.93 %، بينما اظهرت النتائج وجود علاقة توافق كبيره بين مركبات سطح البحر المتبقية (النتيجة عن جميع العوامل عدا العوامل المدرية) بنسبة معامل تصل الي 98.06%. وعلاوة علي ذلك، أثبت التحليل التوافقي البسيط أن المركبات المدارية النصف يومية واليومية هي المركبات الأكثر سيطره وشيوعا والأكثر تأثيراً في المنطقة. وعلاوة علي ذلك، ومن نتائج التحليل التوافقي البسيط تم تصنيف المدر والجزر في المنطقة أنه مدر نصف يومي مختلط وذلك بحساب قيمته من معامل التكوين، والذي حقق 0.85، والذي توافق مع نتائج الدراسات السابقة التي استخدمت نموذج سطحي لتمثيل المياه ونموذج محيطي ثلاثي الأبعاد. تم حساب نسبة عدم التوافق للمدر والجزر والتي تعتبر من أهم العوامل التي تعبر عن حركة الترسبيات في الميناء، و كانت النسبة 0.0191 و 0.0193 بالترتيب لكل من بيانات سطح البحر المقاسة والممثلة بالترتيب، وتشير هذه النسبة الي وجود تشوه في موجه المدر والجزر في منطقة الدراسة مع زيادة

حركة الجذر والتي تؤدي الى خروج الترسيبات من الميناء. واخيرا، من نتائج حسابات أقل منسوب مدري فلكي لاستخدامه كأساس للخريطة البحرية لكلا البيانات (المرصودة والممتلئة) والخاصة بمستوى سطح البحر، وجد أن السطح بقيمة 1.57 م تحت متوسط منسوب سطح البحر والذي يعد اكبر عمقا من المستوي المحسوب بقيمة لا تقل عن (5 سم) عن طريق مجموعه مساحه النفط الأوروبيه أثناء إنشاء الميناء عام 2004.

### **Abstract:**

Sea level as a major oceanographic parameter is always needed in the field of hydrographic surveying for Chart Datum (CD) realization. Lowest Astronomical Tide (LAT) is a physical surface and the most recent used tidal datum as defined by the International Hydrographic Organization (IHO); "The lowest tidal level may occur under average meteorological conditions and under combination of any astronomical conditions" (IHO, 2011). It was adopted to be used as the vertical tidal datum for depths reduction on nautical charts. In the current paper, the main objective is to calculate the height of (LAT) referred to the mean sea level in Al-Ahmadi harbor, Kuwait. Sea level data were measured by sea level sensors using offshore Acoustic Doppler Current Profiler (ADCP). Simulated sea level time series was acquired from Delft-3D hydrodynamic model, and then it was used for chart datum calculation. Both observed and modeled sea level series were analyzed using harmonic analysis technique, to separate tidal from non-tidal components. Results of both data sets modeled and observed (tidal and non-tidal signals) were cross-correlated for model validation. Results showed a strong direct correlation between both tidal and residual components from both data sets by 97.93 % and 98.06 % respectively. Furthermore, from harmonic analysis it was found that M2 (Principal lunar semi diurnal), K1 (principal luni-solar diurnal), O1 (principal lunar diurnal) and S2 (Principal solar semi diurnal) are the most significant and dominant tidal constituents in the area. Moreover, tidal type regime Form Factor (FF) ratio shows a mixed semi-diurnal tidal regime by (0.85). These outcomes agree with the results obtained by (Pous, 2012; and Akbari, 2016) using shallow water model and 3D coastal ocean model respectively, for the same area. The tide asymmetry ratio, which is regarded as the major representation of harbor sediment transport, was 0.0193 and 0.0191, respectively, for both observed and modeled datasets, indicating that there is a distortion in tide wave in the area, with ebb-dominant outflow sediment transport away from the harbor. Finally, from modeled sea level dataset, LAT as Chart-datum in the area was found (1.57 m) below Mean Sea Level (MSL), which is higher than the one calculated by the European Petroleum Survey Group (EPSG 5188) during mina Al-Ahmadi refinery construction in 2004 by (5 cm).

**Keywords:** (Modeled Sea level, Delft-3D flow, tidal datum, LAT and HAT, MACD).

## 1- Introduction

The Arabian Gulf and its coastal areas are the world's largest single source of crude oil and related industries which dominate the region. The rapidly increasing needs to explore, drill and transfer oil and gas led to enormous acquisitions of high quality hydrographic and hydrodynamic researches. Arabian Gulf is considered a semi-enclosed basin connected to the deep Gulf of Oman through Strait of Hormuz (Johns et al., 2003). Al-Ahmadi harbor is located at the southeastern part of Kuwait at the position (29.0696°N, 48.1789°E) as shown in Figure (1), and it's considered the principal harbor for crude exports product and gas. The refinery and harbor are located 45 kilometers south of Kuwait City on the Arabian Gulf. This coastal zone has a tremendous effect on global economy, due to its rich resources of gas and oil, which made it one of the critical waterways in the world. Due to this importance, Arabian gulf generally and Kuwaiti harbors specifically have subjected to several studies and master development plans. Nevertheless, there is still a need for more oceanographic and hydrographic studies especially in the discipline of sea level.



**Figure 1. Location of the study area located on the Persian Gulf.**

As a result of global warming and its effect on sea level, it became a field of several studies (Al- Jeneid et al., 2008). Consequently, global Sea level rose rapidly by about 3.1 mm per year from 1993 to 2003, as compared to the average rate of 1.8 mm per year from 1961 to 2003 (IPCC, 2007), Church and White in 2011, estimated the increase of Global Mean Sea Level (GMSL) from 1880 to 2009 was 21 cm, the rate of (SLR) was  $3.2 \pm 0.4$  mm/year (1993 to 2009), then (1900 to 2009) as

$1.7 \pm 0.2$  mm/year which shows twice the value. While, sea level value varied in the northwest part of the Arabian gulf. Several researches were made in the area using sea level data observed from 2 tide gauges. Sultan et al., (1995) concluded in their results from 10 years (1980-1990) that (SLR) is constant by about  $2.1 \pm 0.1$  mm per year. A rate of  $2.34 \pm 0.07$  mm per year was announced by (Hosseinibalam et al.2007) using 9 years of observed data (1990-1999).

Precise determination of LAT referenced to (MSL) in Al-Ahmadi harbor has to cope with the new advanced charting technology to fulfill the most recent LAT definition of the (IHO). The technical resolution of the IHO stated that LAT should be adopted as (CD), where tides have a considerable effect on the water level. The chart datum was chosen as a surface that is so low that the tide will not frequently fall below it, not so low as to be unrealistic and only gradually varying between adjacent datum (FIG,2011).

Delft3D-FLOW model is a progressive combined computer software that carries out model of unsteady flow and transport processes that outcomes from tidal and non-tidal meteorological forcing on a well fitted rectilinear boundary grids (Delft-3D, 2014).Delft-3D is a program consists of numerous modules, each module covers a varied series of aspects, clustered around a reciprocated interface, capable of interrelate with one another, each module can be implemented autonomously or in association with other modules.

This (CD) needs to be re-calculated and updated regularly as a consequence of (SLR), using continuous measured sea level data. So, according to what mentioned, and due to the scarcity of observed data, a consistent and continuous modeled sea level data for 19 years was accounted to replace the observed data. For the purpose of nautical chart production, this data should be validated and analyzed very carefully (Baqer et al., 2011), to provide stakeholders with a complete description of tidal datum for the right decision for the future plans. In this study, a 2-dimensional hydrodynamic model by Delft-3D was implemented to simulate sea level using the flow module in Al-Ahmadi

harbor. Water level time series was acquired and validated using observed sea level data from an (ADCP) with sea level sensor. Harmonic analysis was executed for both observed and simulated time series to get the significant and dominant constituents in the area of study. This research article aims to precisely update and re-define the Kuwaiti tidal (CD), applicable in the area in front Al-Ahmadi harbor on the Arabian gulf. The main objective of this study is to establish an approximate and quick Tidal Level (TL) for hydrographic surveying process and dredging works using short-term modeled offshore sea level data after being validated by observed sea level data.

## 2. Data and Methods of Analysis

### 2.1. Data

The available data used for this study were classified as follows:

#### 2.1.1. Observed sea level:

Although the available observed sea level data is not adequate enough for accurate tidal datum calculation, it was used for model validation and boundary condition. Observed sea level data in this paper acquired from two offshore (ADCP, Nortek Aqua dopp) with 15-minutes time step (from 7th of December, 2019 till 7th of January, 2020), and it was divided according to the location as depicted in Figure (2) as follow;

**A-** Sensor "A" deployed at a depth of 10.8 relative to (MACD), at the geographical position (29°04'02.7"N 48°09'24.7"E) that was the first data set through which the simulated sea level data at the same location was compared, cross correlated and validated.

**B-** Sensor B deployed at a depth of 4.2 relative to (MACD), at the geographical position (29° 4' 27.7" N, 48° 9' 15.9" E) that was the second observed sea level data set by which the flow model boundary condition was created.



Figure 2. Location of ADCP sensors located in AL-Ahmadi harbor, Kuwait.

#### 2.1.2. Meteorological Parameters:

A 1-minute time step weather data from (1st of June, 2019 till 2nd of February, 2020), including both wind speed and direction, surface temperature and atmospheric pressure, which was recorded for further computations and accurate flow simulation modeling.

#### 2.1.2. Bathymetric data:

Bathymetric data in Easting, Northing and depths (X, Y, Z) file format was acquired during a hydrographic surveying project, using multi-beam echo sounder (R2Sonic 2024), compiled by HYPACK 2009 a computer software program.

## 2.2. Methods of Analysis

### 2.2.1. Observed data smoothing and filtering

One-month of observed sea level data sets with no gaps acquired from (ADCP) were arranged and checked for mistakes, outliers and spikes, then smoothed as shown in Figure (3).

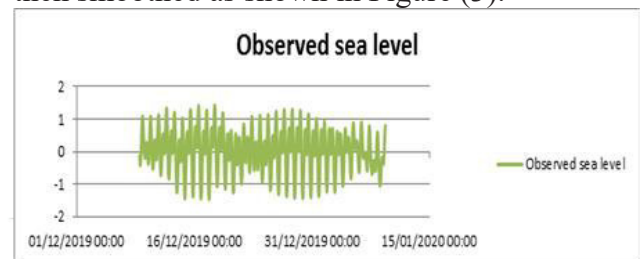

Figure 3: Sensor A and sensor B sea level raw data (from 7th of December, 2019 till 7th of January, 2020) and vertical axis is sea level in meter and the horizontal one is in days.

As shown in Figure (3), From plotted data it is obvious that the signals display tidal harmonic pattern, which means that tidal components are dominated with slight effect of residuals due to non-tidal parameters such as meteorological parameters.

### 2.2.2. Hydrodynamic flow simulation

Delft3 D-FLOW model was used to simulate two-dimensional (2D) of one computational layer for unsteady flow inside Al-Ahmadi harbor. Model was initiated using land boundary file drawn by Google earth pro, bathymetric data well fitted and linearly interpolated on a rectilinear grid of the study area as shown in Figure (4). Tide generating

force and meteorological forcing besides the density effect, were used as inputs for the model development.

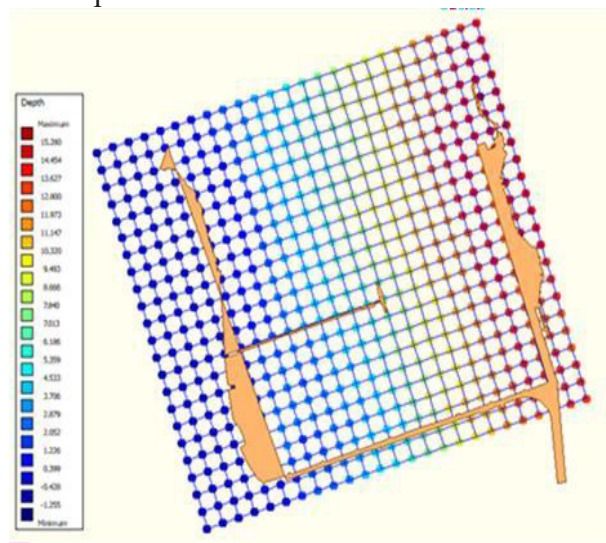

Figure 4. Land boundary file created by Google earth pro, bathymetry file well fitted to the rectilinear grid cell corners created by Delft-3D

The Master Definition File (MDF) was created sensibly starting with collecting attribute files created while initiation such land boundary file for harbor delineation. Rectilinear grid file was built with a grid size (60\*60) m<sup>2</sup> after being well smoothed and orthogonalized. Bathymetric data file, and other interfaces exist while building (MDF) were represented in the latitude (29.31 deg.) to consider a fixed Coriolis force in the entire area, orientation of the grid cells was (342 deg.) clockwise. Flow simulation duration was one month for the time interval from (7th of December 2019 till 7th of January 2020), and time step 0.15 minute. Thin dams were set in the (eastern, southern and T shape out of shore line of the harbor) as shown in Figure (5) in yellow lines, to prevent flow exchange between the two sides of the harbor. Furthermore, the only open boundary that permits flow to exchange was made in the north boundary as shown in Figure (5) with blue line. Boundary conditions were prescribed at the north boundary (Begin and End) points, characterized by the (6, 23) and (25, 23) indices respectively. While values of points that lie in between these two points were computed by linear interpolation. Sea level time series from ADCP sensor (B) was used as boundary conditions.

Meteorological effects represented by wind and temperature parameters were taken into consideration as a uniform wind data file. The (MDF) was ready to run after clarifying the monitoring point at ADCP sensor (A) at (16,7) as shown in Figure (5) to check the results.

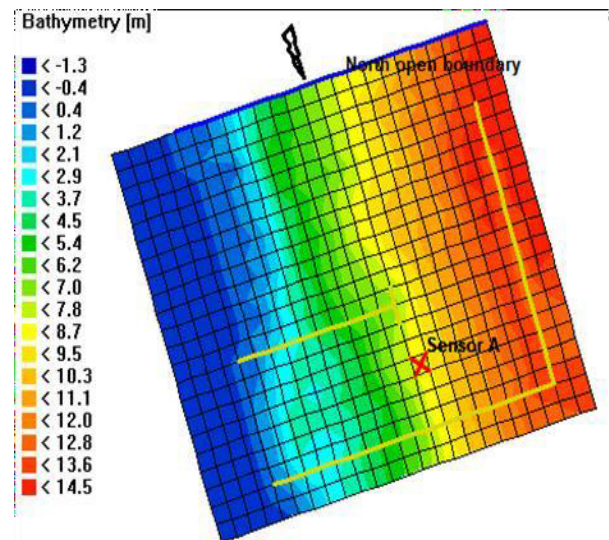

Figure 5. Visualization of all MDF parameters created by Delft 3D flow module

The model was run 2 times, using a laptop (Intel(R) Core(TM) i7-6500U CPU @ 2.50GHz, 2.60 GHz and 8 GB RAM). Using different methods of logging in meteorological parameters inside the (MDF), whether it's a space varying or a uniform wind data file.

1- The first run lasts for 1.5 h, created with a space varying wind and pressure file.

2- The second run, created using a uniform wind data file, and it took about 1.5 h.

The second run showed better results for simulated sea level data, tidal harmonic constants with a high degree of precision when compared with the observed sea level data.

## 2.2.2. Harmonic analysis

Tidal harmonic technique was used for sea level data analysis to discriminate astronomical tidal constituent heights and its relevant frequencies (Pugh, 2004). Tidal Analysis used iteration procedure which is a trial and error process to calculate amplitudes of each tidal constituent component for frequency and phase. These set of amplitudes and phases decided by the

Analysis are called Tidal Harmonic Location Constants (Pugh, 2004).

By using the results from the analysis, the Mean Sea Level (MSL) for the study area, the chart datum at the area of interest can be realized (Pugh, 2004; Tonbol, 2013; and Khedr et al., 2018). Delft3D-software tide suit converts the data obtained from sensor (A) into tidal harmonic constituents (Bazli, B. H., & Joanes, and J. 2016), by which tide signal can be predicted for any date in the future or in the past (Pugh, 1987; Jorda et al., 2012). Delft-3D is mainly dependent on the concept of expressing the amplitudes of tides at any location as the sum of the whole harmonic constituents (Pugh, 1996), as follows:

$$h(t) = H_0 + \sum_{i=1 \text{ to } n} f_i H_i \cos(\alpha_i t + \{V_0 + u\}_i - k_i)$$

Where:

$h(t)$  Tide height at any time  $t$ , above a datum.  
 $n$  : Number of constituents used in tide prediction.

$H_0$  : The mean sea level above the datum.

$H$  : Amplitude of the tidal constituent.

$\alpha_i$  : Angular speed (degrees/hour) of tidal constituent.

$t$  : The time from initial epoch (hours).

$k_i$ : Tidal constituent epoch relative to the transit of the moon over the location of tide.

$f_i$ : Tidal constituent node factor.

$\{V_0 + u\}$  : Tidal constituent equilibrium argument at  $t = 0$  (degrees).

$(\alpha_i t + \{V_0 + u\} - k_i)$ : The phase at any time  $t$  relative to the transit of the moon.

The obtained heights consist of two components tidal and non-tidal. Astronomical tidal constituents were calculated using least square method in delft-3D then subtracting all astronomical component heights from simulated sea-level heights. Non-tidal components were obtained from the residual signal (Eid, 1990; and Svensson and Jones, 2004).

### 2.2.2. Model validation

Cross correlation method of analysis was done for model validation, by estimating the relationship

between modeled and observed sea level datasets at the same time span. Cross correlation statistical analysis was used to understand the relation between the two independent variables, by exploring the form and strength of this relationship, besides, the time shift for best correlation results. Both data sets, tidal components and the residuals were cross correlated using MATLAB code.

Root mean square error is an analytical expression which is very similar to Standard deviation (SD) in the sense that RMSE refers to  $N$  data points instead  $N-1$ . RMSE can be Expressed by equation (2).

$$RMSE = \sqrt{\frac{1}{N} \sum_{i=1}^n (O_i - S_i)^2} \quad (2)$$

Where:

$o_i$ : Observed sea level value

$s_i$ : Simulated sea level value

$N$ : Number of observed points

RMSE which is considered an evaluation for numerical predictions as a general- purpose error metric, has the same unit of  $O_i$  and  $S_i$ , can sometimes be expressed in.%

### 2.2.2. Form factor

By using the resultant amplitudes of the four major tidal constituents, tidal cycle type in the area of study was determined using the following form factor equation (Pugh, 2004):

$$F = (H_{O1} + H_{K1}) / (H_{M2} + H_{S2}) \quad (3)$$

Where:

$H_{O1}$ : The tidal amplitude of the principal lunar diurnal constituent.

$H_{K1}$ : The tidal amplitude of the luni-solar diurnal constituent.

$H_{M2}$ : The tidal amplitude of the principal lunar semidiurnal constituent.

$H_{S2}$ : The tidal amplitude of the principal solar semidiurnal constituent.

According to the value of the form factor  $F$ , the type of a tidal oscillations may be considered as follows (Pugh, 2004):



The constituent factor F

Range	Tidal cycle type
0 to 0.25	semidiurnal
0.25 to 1.5	mixed semidiurnal
1.5 to 3	mixed diurnal
larger than 3	diurnal

## 2.2.6. Tide Asymmetry

Asymmetry is frequently defined as the distortion occurred in the tidal wave. Tidal asymmetry is characterized by imbalanced falling and rising tidal periods and unequal peak flood and ebb currents (Pugh, 1987; and Prandle, 1991). According to the results of tidal analysis and in terms of harmonic constituents, tidal asymmetry is reflected by the interaction between M2 and its over-tides such as M4 and M6, which are 2 times and 3 times in frequency of the basic M2 tide (Speer and Aubrey, 1985; Friedrichs and Aubrey, 1988). It has been found that M4 is the main provider for the distortion of tidal wave in this coastal areas (Friedrichs, , 1988). A ratio of M4 and M2 was used for distortion degree expression and asymmetry of the tides.

$$Ar M4 = \frac{M4_{amp}}{M2_{amp}}(4)$$

where Ar is the amplitude ratio; Ar M4 > 0.01 indicates a significant distortion in the tide wave.

$$\phi M4 = 2\theta M2 - \theta M4 (5)$$

Where  $\theta$  shows the phase. If  $0 < \phi M4 < 180$ , the flow is classified as flooding flow. If  $180 < \phi M4 < 360$ , the flow is considered as ebb-dominant. This relationship is considered a complete definition of sediment transport. If the harbor is flood- dominant, the transport of sediment is towards the interior of the harbor that lead the decision makers for dredging process from time to time. In contrast, if the harbor is ebb-dominant, sediment tends to be transported out of the harbor (Dias, 2013).

### 2.2.2. Energy Percentages of both Tidal(TP) and Residual (RP).

Amplitude percentage of both tidal and non-tidal signals were calculated and compared to the sea

level absolute value in meters, to acquire amplitude energy percentage of both tidal and non-tidal components. Power percentages of both tidal and residual signals were calculated referred to the total sea level signal using the Formulas (6) and (7), which was written in MATLAB code;

$$RP \% = [MRP / (MRP + MTP)] \times 100\% (6)$$

$$TP \% = [MTP / (MTP + MRP)] \times 100\%(7)$$

Where: Residual Power Percentage is (RP %), and (MRP) is Mean Residual Power, while (MTP) is the Mean Tidal Power.

### 2.2.2. Tidal Datum calculations

Tidal datum heights were calculated using the equations figured by (Khedr et al, 2018), using a MATLAB code according to latest (IHO) definition of (LAT) and (HAT).

$$HAT = 0 + \text{mean\_sea\_level} + \text{abs}(\text{max\_tid\_level}) + \text{abs\_average\_resd.} (8)$$

$$LAT = 0 + \text{mean\_sea\_level} - \text{abs}(\text{min\_tid\_level}) - \text{abs\_average\_resd.} (9)$$

Other tidal datum heights were calculated based on the amplitude values of the four major harmonic constituents (M2, S2, K1, O1) acquired from harmonic analysis (Khedr et al, 2018).

The procedure and analysis methods used in this work took into account the following:

- 1- Available sea level data sets, measured wind data and all (MDF) attribute data files were prepared, filtered and rearranged using Microsoft Excel.
- 2- Delineation of land boundary of Al-Ahmadi harbor and bathymetric data files filtered and interpolated using Google Earth pro and Hypack 2009a.
- 3- Flow model simulation was run for extracting simulated sea level data using Delft-3D program flow module.
- 4- By tide suit Delft-3D, harmonic analysis technique was used to decompose the signal into its two components (tidal– non tidal) components.
- 5- Using MATLAB Codes for data validation, time lag determination, (PSD)

charting and judging the tidal and non-tidal energy, and tidal datum (most used) calculation (LAT, HAT).

### 3. Results and discussion

After running the flow model for about one and half hour to simulate sea level time series. A time series of sea level was obtained with time step 15 minute from (from 7th of December, 2019 till 7th of January, 2020) as shown in Figure (6) at the same location of sensor (A).

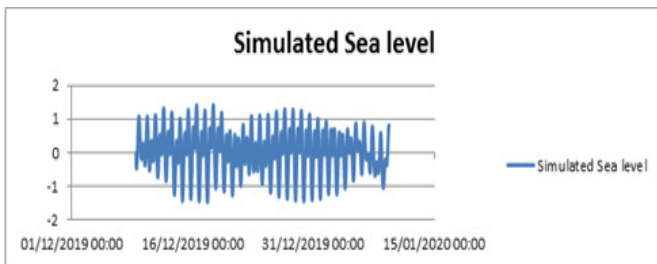

Figure 6. Simulated sea level data at sensor (A) resulted from model simulation from (7th of December, 2019 till 7th of January, 2020).

The resulted simulated sea level signal appeared to be similar to the observed sea level.

#### 2.1. Harmonic analysis

Harmonic analysis used for both data sets, observed and simulated, was made using tide module in Delft 3D. Program algorithm identified amplitudes of 30 tidal components, with only 14 significant constituents that supposed to represent tidal energy in the area of study as shown in Figure(7). Residual components of both data sets were illustrated in Figure (8) after subtracting the harmonic component from the original signal.

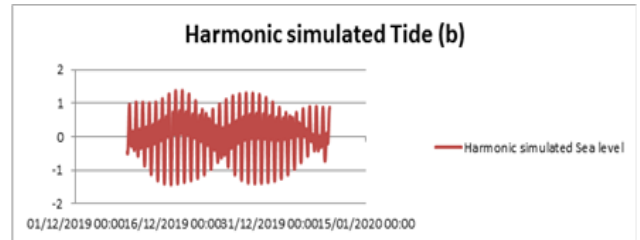
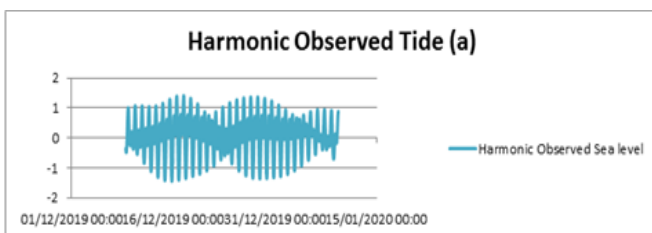

Figure 7: Harmonic component of the significant tidal constituents from the: a) Observed sea level data at sensor (A); b) Simulated sea level data at sensor (B).

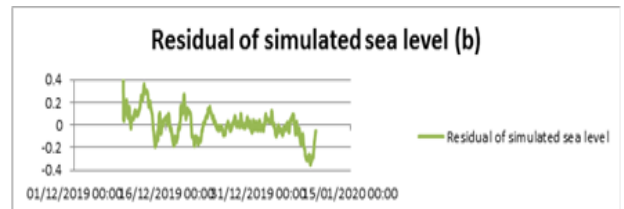
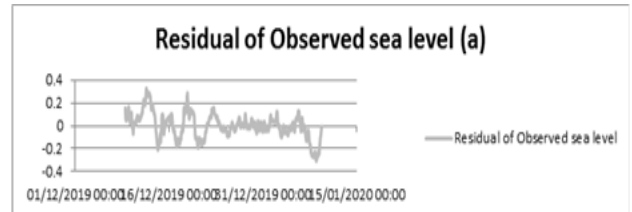

Figure 8: Residual component of the: simulated sea level data sensor (A); simulated sea level data sensor (B).

Table 1. Amplitudes and phase of Significant tidal constituents' parameters from harmonic analysis for simulated and observed data.

constituents	Amplitudes (cm.)			Phase(deg.)	
	Simulated Data	Observed Data	Diff	Simulated Data	Observed Data
M2	62.2	62.7	-0.5	293	307.4
K1	45	45.3	-0.3	120.9	128.5
O1	26.7	27	-0.3	42.9	50.1
S2	21.3	21.4	-0.1	29.1	43.8
P1	14.7	14.9	-0.2	120.9	128.5
N2	11	11.1	-0.1	242.3	256.5
Q1	7.5	7.5	0	20.2	27.7
MFM	6.3	6.4	-0.1	286.2	293
K2	6	6.1	-0.1	29.1	43.8
MK3	4.6	4.8	-0.2	23.1	45
MQM	3.7	3.4	0.3	203.7	209.4
2K01	3.5	3.6	-0.1	47	55.6
O2	2.6	2.6	0	42.9	57.8
MF	2.3	1.6	0.7	232.3	244.8

Tidal constituents in the diurnal and semi-diurnal bands such as; (K1, P1, O1, M2, S2, K2 and N2) were noticed with almost same amplitudes and phase angles with slight differences in both ranged data sets ranged from 0.7 cm in MF to -0.5 cm in M2 in amplitudes. While the phase differences were within 14 deg. for the significant tidal constituents. The most significant tidal constituents S2, K2, O2 and N2, were matching. The difference between the simulated sea level data and the observed one are smaller than 5%.

**Table2. Amplitudes of Significant tidal constituents' parameters from harmonic analysis for both simulated and observed data sets with (FVCOM)**

constituents	Simulated Data cm	Observed Data cm	(FVCOM) cm. (Akbari, 2016)
M2	62.2	62.7	63.3
K1	45	45.3	43.2
O1	26.7	27	29.3
S2	21.3	21.4	17.2
P1	14.7	14.9	14.2
N2	11	11.1	12
K2	6	6.1	5.3

For both observed and simulated data harmonic analysis results, a validation of both data sets was given in table (2) with the previous study of Akbari (2016) who used the coastal ocean model (FVCOM). Comparing results showed agreement with the significant tidal constituents with a maximum difference 3.2 cm for S2 and minimum difference of 0.4 cm for K2.

## 2.2. Cross correlation for model validation

Model results were also validated by available observed sea level data acquired from sensor (A) using a cross-correlation technique as shown in Figure (9). After harmonic analysis by tide module in Delft 3D for both data sets, theharmonic components were cross correlated as shown in Figure (10), furthermore the residual components as shown in Figure (11).

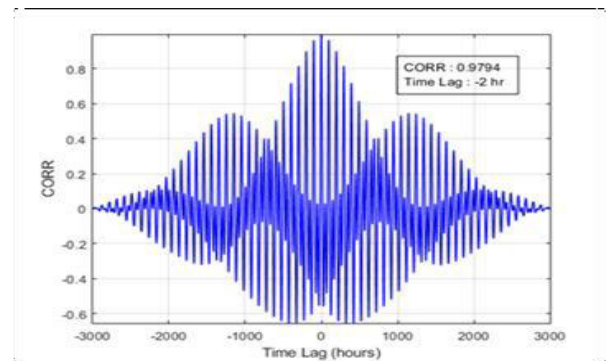

**Figure 9. Cross correlation (0.9794) and time lag (-2 hr.) between modeled and observed sea level data during the time period (07/12/2019 - 07/01/2020)**

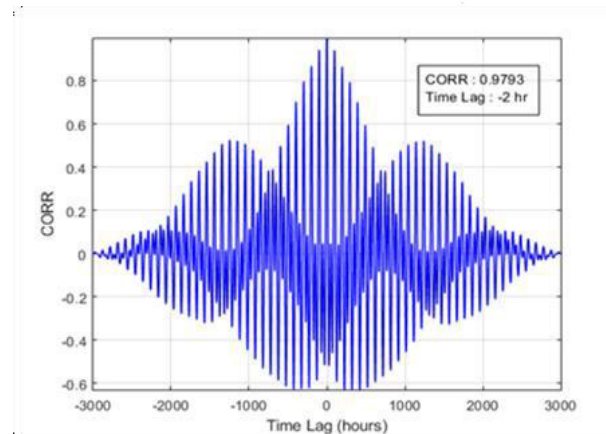

**Figure 10. Cross correlation (0.9793) and time lag (-2 hr.) between modeled and observed tidal signals during the time period (07/12/2019 - 07/01/2020)**

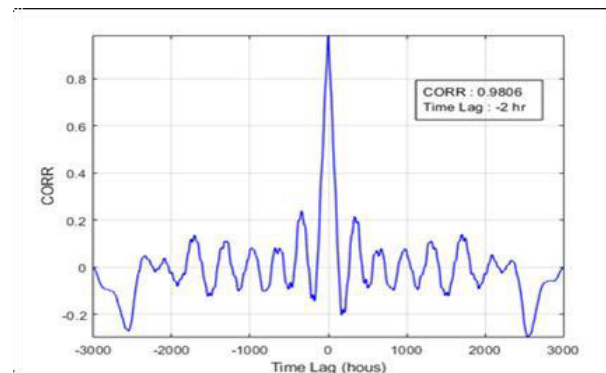

**Figure 11. Cross correlation (0.9806) and time lag (-2 hrs.) between modeled and observed residual signals during the time period (07/12/2019 - 07/01/2020)**

Fluctuations of both data sets at the same location of Sensor (A) were compared as shown in Figure (9), and it was found that there is a strong direct correlation noticed in the phase of the two tidal signals by approximately (97.94 %), moreover the mean difference

is 0.03 m. Root mean square error was calculated using equation (2) and was found to be 0.13 m, furthermore, in Figure (10), (X corr) between tidal components by (97.93 %), the mean differences is (-0.03 m) and (RMSE) is (0.13 m). While residuals components in Figure (11) shows a value of (98.06 %), and (RMSE) is (0.04 m). The values of cross correlation analysis which is considered a measure of similarity between the two-time series, mean differences and (RMSE) showed good agreement between model results and the observed sea level data.

## 2.2. Tidal cycle determination

To classify the nature of tide in the study area, the Form Factor was applied by equation (3) and the results are indicated in Table (3).

Table 3. The amplitude of the four major dominant constituents in the area

No.	Simulated data		Observed data	
	Constituents	Amp.(cm)	Constituents	Amp. (cm)
1	O1	26.7	O1	27
2	K1	45	K1	45.3
3	M2	62.2	M2	62.7
4	S2	21.3	S2	21.4

For both observed and simulated data, the tidal type regime was found to be a mixed semi diurnal as the calculated Form Factor was 0.85 which agrees with the results obtained by V.C. John in 1988.

## 2.2. Tide Asymmetry

Table (4) shows the dominant constituents in sediment transport, by using equation (4) it was found that the amplitude ratio for simulated and observed constituents 0.0193, 0.0191 respectively. Using equation (5) by the given phase shows that  $180 < \phi_{M4} < 360$ .

Table 4. The amplitude and phase of the three dominant constituents in tide asymmetry sensor (A)

No.	Simulated data			Observed data		
	Constituents	Amp. (cm)	Phase (deg.)	Constituents	Amp. (cm)	Phase (deg.)
1	M4	1.2	304.4	M4	1.2	332.8
2	M2	62.2	293	M2	62.7	307.4

According to tide asymmetry and the Ar M4, there is a significant distortion in tide wave. Value of  $\phi_{M4}$  is an indication that ebb is dominant in the harbor, which means that transport tends to be out of the harbor.

## 2.3. Power Spectral Density

The different tidal constituents power could be expressed by its power spectrum. According to harmonic analysis by Delft-3D tide module and the resulted significant constituent's frequencies, it's realized that the highest power peaks are found at the most dominated frequencies affecting the analyzed time series.

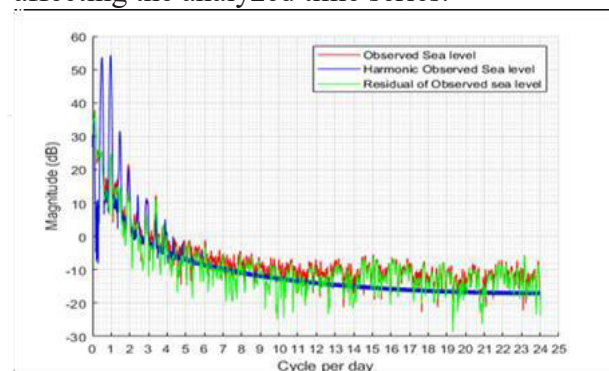

Figure 12. Power spectral density (PSD) showing the observed sea level (red), extracted tidal energy (blue) and residual energy (green) inside Al-Ahmadi harbor (07/12/2019 - 07/01/2020)

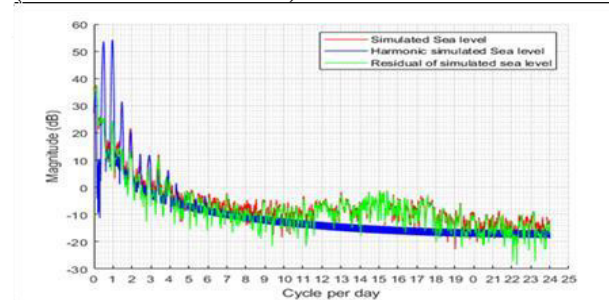

Figure 13. Power spectral density (PSD) showing the simulated sea level (red), extracted tidal energy (blue) and residual energy (green) inside Al-Ahmadi harbor (07/12/2019 - 07/01/2020)

From Figure (12), it appears that the energy peaks coincided with significant frequencies associated with diurnal constituents such as (K1, P1 and O1) and semidiurnal such as (M2, S2, K2 and N2).

Figure (13) shows the same results for simulated sea level data set with diurnal constituents (K1, P1 and O1) and semidiurnal such as (M2, S2, K2 and N2).

## 2.2. Residual and Tidal Power Percentage

Power percentages of both residual and tidal signals to the total sea level signal were calculated, using the output signals resultant from harmonic analysis. Power percentages have been calculated for both data sets as shown in Table (4).

Table 4. Power percentages of tidal and residual signals to the sea level total signal

Components	Power percentages	
	Observed Sea Level	simulated Sea Level
Residual Power	3.79%	3.34%
Tidal Power	96.21%	96.66%

## 2. Tidal Datum Calculation.

Even though the ADCP sensor ellipsoidal height is missed. furthermore, the vertical datum definition needs more computations in order to be realized. The Tidal levels well defined by IHO can be calculated using equation (8) and equation (9) which was validated lately by European Petroleum Survey Group (EPSG:5188) that states that (MACD) is 1.52 below (MSL). In this thesis (LAT) and (HAT) were calculated to be 1.57 below (MSL) and 1.52 above (MSL) respectively. Other tidal datum was also computed related to (MSL) following (Khedr et al., 2018) and were as shown in table (5).

Table 5. the values of tidal datum calculated from the simulated sea level data during the period of (07/12/2019 - 07/01/2020)

Tidal datum	value (cm)
(MHWS)	83.5
(MLWS)	-83.5
(MHWN)	40.9
(MLWN)	-40.9
(HHWL)	155.2
(LLWL)	-155.2

## 4. Conclusions:

The flow model of Delft-3D was proved to be a reliable tool for numerical simulation for flow. Validation of simulated sea level data with observed data set at the same location and same period of time showed a strong X-correlation of about 97.94 % and RMSE 0.13 m. From harmonic analysis by the tide suite Delft-3D, it was noticed that there are 14 significant tidal constituents in the area including the main dominant diurnal and semidiurnal tidal constituents (K1, P1, O1, M2, S2, K2 and N2). Comparing results of both simulated and observed data sets, it's reflected that the main tidal constituents are almost the same with slight differences, even with previous studies by (Pous, 2012; Akbari, 2016). Tidal type regime calculated (FF) value is (0.85) which induced mixed semi-diurnal tidal regime in the area. Tide asymmetry showed a distortion in tidal wave with an ebb tide dominant in the study area. From power spectral density, a significant tidal power was noticed, diurnal and semi-diurnal bands (K1, P1, O1, M2, S2, K2 and N2). From relative power percentage calculations of both tidal and residual signals to the total sea level signal after demeaning both signals, both tidal and residual have almost the same effects to total sea level. Tidal datum levels were calculated and showed an acceptable value compared with the European Petroleum Survey Group 5188, with a difference of 5 cm.

## 5. Recommendations for Future Research

This work shows a short period flow model simulation, although the flow model results were validated Using statistical methods and previous studies. Observed sea level data for a nodal cycle should be provided for more accurate results. A continuous update of vertical datum calculation is needed for tidal datum realizations

For the study area. A wave rider sensor is recommended to be fixed with Acoustic Doppler current profiler to get offshore wave data which can be coupled with Delft-3D flow module to compute the effect of flow on waves. The dominant tidal constituents in the study area can be easily used for tide prediction.

## References

Al-Jeneid, S., Bahnassy, M., Nasr, S., Raey, M.E., (2008) Vulnerability assessment and adaptation to the impacts of sea level rise on the Kingdom of Bahrain. *Mitig. Adapt. Strateg. Glob. Change* 13: 87-104

Aubrey, D. G., and P. E. Speer (1985), A study of non-linear tidal propagation in shallow inlet/estuarine systems part I: Observations, *Estuarine Coastal Shelf Sci.*, 21: 185-205.

Baqer, M. M., Eman, A., Gopi, S., Renati, K., Al khatib Al., and Subbaraju, K., (2011); "Establishing and Updating Vertical Datum for Land and Hydrographic Surveying in Dubai Emirates", Marine/Coastal Modelling and Technology, FIG Working Week 2011, Bridging the Gap between Cultures, Marrakech, Morocco.

Bazli, B & J., Joanes. (2016). Stream Prediction for Tidal by Algorithm of GeoTide.

Church, J.A., White, N.J., 2011. Sea-level rise from the late 19th to the early 21st century. *Surv. Geophys.* 32: 585-602

<http://dx.doi.org/10.1007/s10712-011-9119-1>

Dias J.M., Valentim J.M., Sousa M.C., (2013) A numerical study of local variations in tidal regime of Tagus estuary 8: e80450.

<https://doi.org/10.1371/journal.pone.0080450>

Eid, F.M., (1990) Variation of surge heights at Alexandria Port (Egypt). *Journal King Abdul-Aziz University (JKAU), Marine Science* 9: 3-18.

Friedrichs, C.T., Aubrey, D.G. (1988) Non-linear Tidal Distortion in Shallow Well-Mixed Estuaries: A Synthesis. *Estuar. Coast. Shelf Sci.* 27: 521-545.

Harvey, N. 2005. Review of Changing Sea Levels: Effects of Tides, Weather and Climate, by D. Pugh. *Oceanography* 18(1):251–252, <https://doi.org/10.5670/oceanog.2005.78>.

Hosseinibalam, F., Hassanzadeh, S., Kiasatpour, A., (2007) Interannual variability and seasonal contribution of thermal expansion to sea level in the Persian Gulf. *Deep Sea Res. I Oceanogr. Res.* (54) 1474–1485  
<http://dx.doi.org/10.1016/j.dsr.2007.05.005>

IHO, (2011); "Resolutions of the International Hydrographic Organization Publication M-3", 2nd ed., available at ([www.iho.int](http://www.iho.int), 2011b).

IPCC, (2013); "The Physical Science Basis Contribution of Working Group I to the Fifth Assessment", The Climate Change Report of the Intergovernmental Panel on Climate Change [Stocker, T.F., D. Qin, G.-K. Plattner, M. Tignor, S.K. Allen, J. Boschung, A. Nauels, Y. Xia, V. Bex and P.M. Midgley (eds.)], Cambridge University Press, United Kingdom, and New York, USA.

Johns, W. E., F. Yao, D. B. Olson, S. A. Josey, J. P. Grist, and D. A. Smeed (2003) Observations of seasonal exchange through the Straits of Hormuz and the inferred heat and freshwater budgets of the Persian Gulf, *J. Geophys. Res.*, 108: C12-3391  
doi:10.1029/2003JC001881.

Jordà, G., Gomis, D., Álvarez-Fanjul, E. and Somot S., (2012) Atmospheric contribution to Mediterranean and nearby Atlantic sea level variability under different climate change scenarios. *Global and Planetary Change*, 80: 198-214.

<https://doi.org/10.1016/j.gloplacha.2011.10.013>

Khedr AM, Abdelrahman SM, Tonbol KM. (2018). Sea level characteristics referenced to specific geodetic datum in Alexandria. *World Acad Sci Eng Technol Int J Mar Environ Sci.* 12: 78-86.

[scholar.waset.org/1307-6892/10008544](http://scholar.waset.org/1307-6892/10008544)

P. Akbari, M. Sadrinasab, V. Chegini, M. Siadatmousavi. (2016). Tidal Constituents in the Persian Gulf, Gulf of Oman and Arabian Sea: a Numerical Study. *Indian Journal of Geo-Marine Sciences* 45: 1010-1016.

Pous, S., Carton, X. and Lazure, P., (2012) A Process Study of the Tidal Circulation in the Persian Gulf, *Open J. Mar. Sci.* 2: 131-140.

Prandle, D. (1991), Tides in estuaries and embayments, in *Tidal Hydrodynamics*, John Wiley Toronto, Ont., pp.125–152.

Pugh, D. (1987) *Tides, Surges and Mean Sea Level: A Handbook for Engineers and Scientists*. Chichester, UK. John Wiley & Sons, 472 p.

Pugh, D.T. (1996) *Tides, surges and mean sea-level*, Chichester, UK. John Wiley & Sons, Ltd., 486pp.

Sultan, S.A.R., Ahmad, F., Elghribi, N.M., Al-Subhi, A.M., 1995. An analysis of Arabian Gulf monthly mean sea level. *Cont. Shelf Res.* 15:1471–1482

[http://dx.doi.org/10.1016/0278-4343\(94\)00081-W](http://dx.doi.org/10.1016/0278-4343(94)00081-W)

Svensson, C., Jones, D.A., (2004). Sensitivity to storm track of the dependence between extreme seas surges and river flows around Britain. *Hydrology: Science and Practice for the 21st Century* 1: 239-245.

Tonbol K., Shaltout M. (2013) Tidal and non-tidal sea level off Port Said. *JKAU: Mar Sci.* 24: 69–83.

V. C. John, (1992) Harmonic Tidal Current Constituents of the Western Arabian Gulf from Moored Current Measurements, *Coastal Engineering*, 17: 145-151.

doi:10.1016/0378-3839(92)90016-N

# Green Port Performance Assessment in the Egyptian Context

Prepared by

Mohamed H. M. Hassan

Ahmed Mohmed Aly Salem

Arab Academy for Science, Technology and Maritime Transport

## المستخلص:

يهدف هذا البحث إلى اختبار أداء الموانئ قبل وبعد تطبيق استراتيجية الموانئ الخضراء. لذلك استخدمت الباحثة الفلسفة الوضعية في هذه الدراسة والمنهج الاستنتاجي لأنها أكثر توافقاً مع طبيعة البحث ومع ما يريد الباحث الوصول إليه. كما اتبع المنهج الكمي في جمع البيانات، حيث قام بإعداد استبيان وتوزيعه على 385 بحاراً. فتم تحليل البيانات باستخدام طريقة إحصائية مثل عينة اختبار "t" المستقلة. وبذلك أشارت النتائج إلى تحسن أداء الموانئ بعد تطبيق استراتيجية الموانئ الخضراء.

## Abstract:

This research aims to test the performance of ports before and after the application of green port. Therefore, the researcher used the positivism philosophy in this study and the deductive approach because they are more compatible with the nature of the research and with what the researcher wants to reach. He also followed a quantitative method in collecting data, as he prepared a questionnaire and distributed it to 385 seafarers. The data is analyzed using statistical method such as independent sample t-test. The results indicated that the performance of ports is better after the application of green ports.

Keywords: Green Port, Performance, Pollution, Energy.



## 1- Introduction

Ports today play a greater role than simply handling cargo on the quayside. The sources of their competition and the extent of their influence stretch across the sea and deep into the hinterland (Aregall et al., 2018). Their management and operational strategies are entwined with stakeholders on several scales and in many spheres, from local to global and from business to government. The port's role in the transport chain has the potential to shape the social and environmental performance of transportation systems extending across the globe. While many ports choose not to act beyond complying with existing environmental regulations in their city, region or country, in many cases they have exercised their potential for addressing both social and environmental externalities (Bergqvist and Monios, 2019).

While the Kyoto Protocol (adopted in 1997 and entering into force in 2005) introduced legally binding emissions targets, aviation and shipping were not included. Researchers have in recent years analyzed and quantified the emissions from the maritime sector, which may form a potential baseline for future targets. While the primary focus of this book is on the port perspective, attention to emissions in the maritime sector has focused for the most part on the output of vessels while at sea. These emissions can be divided broadly into greenhouse gas (GHG) emissions affecting climate change and local air pollution, primarily sulphur oxides (SO<sub>x</sub>), nitrogen oxides (NO<sub>x</sub>) and particulate matter (PM) (Bergqvist and Monios, 2019).

In 2007-2012, shipping accounted for 2.8% of global GHG emissions or double the level produced by air travel. Local pollutants are a more pressing issue in coastal areas due to their impact on human health (Bergqvist and Monios, 2019). The World Health Organization (WHO) considers air pollution a major environmental risk to health, estimating that it results in three million deaths per year (World Health Organisation, 2016).

Shipping contributes a significant amount to this risk, especially in coastal areas. Worldwide, shipping accounts for approximately 15% of NO<sub>x</sub> and 5-8% of SO<sub>x</sub> emissions (Zis et al., 2016) which cause serious harm both to human health and to the environment. It was found that

emissions from shipping caused about 50,000 premature deaths in Europe alone in 2000 (Bergqvist and Monios, 2019).

When thinking of sustainability in shipping and ports, most of the focus tends to be on air pollution; however, as shown through the diversity of topics covered in this volume, there are many other areas of importance for green ports such as noise, dust, waste and water pollution (Lam and Notteboom, 2014).

Green port management must also include the broader topic of ecosystem protection through port sustainability plans and environmental planning regulations (Schipper et al., 2017). In addition, we also consider the issue of socioeconomic analysis and planning (Dooms et al., 2015) as relevant to a complete understanding of green ports (Bergqvist and Monios, 2019).

## 2. GREENING PORT IMPORTANCE

Maritime transport is the backbone of international trade and a key engine driving globalization. Around 80 percent of global trade by volume and over 70 percent by value are carried by sea and are handled by ports worldwide in 2012 (Dumitrescu, 2014). In 2021, the global trade become over 80 percent of world trade by volume according to UNITED NATIONS CONFERENCE ON TRADE AND DEVELOPMENT (UNCTAD).

These shares are even higher in the case of most developing countries. As transfer traffic continues to grow, this grow of ensuring the long-run sustainability is playing an increasingly important part in the policy debate on globalization, trade and development, environmental sustainability, energy security and climate change (Chiu et al., 2014).

Seaports connect the world through maritime transportation networks, promote international trade, and support global economic growth (Lee et al., 2018). The anthropogenic inputs of environmental pollution can be the checkpoint through maritime transportation activities, which presents new and critical challenges to port managers regarding the provision of efficient port services and utilization of their unique position to curb global environmental problems (Luo and Yip, 2013). The concept of green porting is important to protect the environment, there are many factors affecting the operation of

a green port (Chiu et al., 2014).

Ports are important gateways for international trade as about 90 percent of global trade tonnage move by ship through ports (Rodrigue and Notteboom, 2013). Being locations where trade, logistics, and production converge; connecting various points of production and consumption, ports are indispensable nodes in global supply chains. Research has however also shown that increasing shipping, which often requires expanding existing port infrastructure with new quays and deeper channels as well as handling increased volumes of cargo, can be associated with adverse environmental externalities (Lawer, 2019).

These include effects on air quality, water quality, biodiversity, emission of greenhouse gases and problems associated with hazardous ship and port generated waste, oil spills and ballast water discharge. Consequently, ports all over the world are under pressure from both local and international arenas to protect the environment, maintain public health and reduce their impacts on climate change (Lawer, 2019).

Generally acknowledged that achieving (environmental) sustainability including at seaports and along the maritime value chain, requires effective policy, management and governance systems (Notteboom and Rodrigue, 2017). Traditionally, the environmental governance of ports followed a centralized nation-state system where national institutions set and enforce rules or pollution limits and require environmental improvements and compliance from port authorities (Lawer, 2019).

In recent years, however, non-state and sub-national actors including port authorities, port cities, terminal operators, and environmental NGOs are taking up environmental responsibilities and positioning themselves as key actors with agency in environmental governance and policy making through various collaborative environmental initiatives and projects (Barnes-Dabban, 2018), especially those that are directly related to shipping and are trans boundary in nature (Lawer, 2021).

### **3. TOOLS OF GREENING PORTS**

Port authorities around the world are pursuing a greening of port management in view of

safeguarding their 'license to operate' and increasing their economic and environmental competitiveness. Port policy charts a port's strategy and development as well as regulates port activities. The government plays an important role as a powerful institution influencing the actions of organizations to improve environmental management (Clemens and Douglas, 2006). However, environmental policies and regulations may impose substantial cost to the extent that such matter becomes a community responsibility rather than just an industry concern (Lam and Notteboom, 2014).

Therefore, how to balance environmental quality and economic feasibility is a key issue. Another challenge in setting environmental policies is the existence of institutional barriers to the integration of such policies with transport and health policies. The barriers include autonomy of government departments, weak connections among the sectors and inefficient procedures in dealing with cross-sectorial issues (Lam and Notteboom, 2014).

The possible tools are; pricing, monitoring and measuring, market access control and environmental standard regulation.

Pricing Strategies can be used to boost a port's competitive position such as lowering charges (port dues or terminal handling charges or both) in order to compete against other ports (Lam, 2016). Ultimately, the pricing scheme should correspond to market conditions and counter competition, stimulate market growth and improve profitability (Yap et al., 2011). In view of the direct relationship between hinterland access and port performance, port pricing should also consider hinterland capacity. It was found that profit-maximizing ports internalize hinterland congestion as far as it affects their customers (Saeed and Larsen, 2010).

Port pricing can promote the efficient use and enhance the utilization rate of the facilities. Another long existing approach is to impose marine pollution penalty. Started in recent years, pricing can also be used as an environmental incentive tool in ports (Lam and Notteboom, 2014).

Access regulation is to control how terminal operators access the facilities they need to

compete in the market. It promotes competition among the operators and has lower intervention costs than using price regulation (Defilippi and Flor, 2008). In relation to market access regulation, a terminal concession or a grant by a government or port authority to a (private) operator for providing terminal operation services has become a popular governance tool in the port industry (Notteboom, 2006).

The design of concession agreement, its regulatory and tariff regimes, as well as the way the concession is awarded are structured to conform to the priorities of public authorities. It was argued that concessions are beneficial to enhancing competition in and between ports only if they are granted to the most efficient port operator. ESPO is in the process of producing a good practice guide, which is primarily aimed to help port authorities improve their contracting methods and instruments in order to gain more value from a governance perspective (Notteboom et al., 2012).

Ports also increasingly implement environmental management system (EMS) which is a systematic approach to manage a port's environmental programmes for pollution prevention, protection and control. It in essence is a documented process that describes a structure for the management of environmental impact processes and continuous improvement (for example, environmental risk assessment and management actions to address those risks) (Du Plessis, 2014).

It was suggested that port and harbor projects should have an environmental management plan, which includes information on the generation and treatment of solid waste, liquid and gaseous effluents, details of safety measures around the project, and details of the safety organization, including key personnel (Lam and Notteboom, 2014).

Monitoring is one of the important aspects in EMS. The UK ports sector responded to environmental legislation with the focus on monitoring mechanism for ports and harbors in maintaining their environmental sustainability (Lam and Notteboom, 2014). Biological indicators such as presence/absence of individual marine species and abundance of dominant species for monitoring purpose were suggested

(Desrosiers et al., 2013).

The major environmental parameters that ports required to be monitored were marine-related issues, water quality, meteorological parameters, turbidity and sediment processes. Indirect effects such as altered transport patterns and increased energy use due to larger built environment should be taken into account in strategic environmental assessment of transport infrastructure investment (Kusnopranto et al., 2017).

#### **4. BENEFITS OF GREENING PORTS TO ENVIRONMENT**

According to the United Nations, the maritime transport is not isolated from climate changes; the type, range, and extent of impacts vary according to local locations, transportations systems, designs, and policies, as well as the capacity to adapt and minimize the costs. Direct impacts are likely in relation to maritime transport infrastructure, operations, and maintenance (Chiu et al., 2014). The services of maritime transport may also be affected indirectly; as a result of changes in demand, induced by climate change effects on trade, investment decisions, agricultural production, demographics, forests, energy demand, energy exploration and fishing activity (Dellink et al., 2017).

Emissions from commercial shipping have been one of the important subjects under intense scrutiny to reduce environmental impacts. There are three main ways to reduce maritime greenhouse gas emissions. Firstly, technical measures include more efficient ship hulls, energy saving engines, more efficient propulsion, use of alternative fuels, such as fuel cells, biofuels, or others, "cold ironing" in ports (providing electrical supply to ships from shore sources), devices to trap exhaust emissions (such as scrubbers), and others, even including the use of sails to reduce power requirements. Secondly, the market based instruments measures are classified into two main categories, emissions trading and carbon levy schemes. Thirdly, there are operational options that mainly involve speed optimization, optimized routing, improved fleet planning, and other logistics based measures (Chiu et al., 2014).

In the context of ship construction and technology, some ships are more environmentally friendly than others by design, as measured by the Energy Efficiency Design Index (EEDI) (Smith, 2012). Newer ships tend to be more energy efficient than older ones as hull and engine designs improve with time, and engines lose efficiency with age and use. Some ports have considered including the EEDI in the determination of port fees, to encourage more energy efficient shipping. Shipping lines now commonly optimize routes with respect to weather and currents to save fuel. Likewise ballast and trim can be optimized to save fuel (Davarzani et al., 2016).

Operationally, in ports, there has been a move to encourage ships to turn off their engines and generators while at berth and connect to a landside electricity supply, a process referred to as "cold ironing" (Zis et al., 2014). Landside electricity may also be used to power cranes and equipment for moving containers, perhaps accompanied by automation. The electrification of cranes opens up the possibility of introducing regenerative technology, enabling electricity to be generated when containers are lowered and reducing crane energy consumption by around 30% (Davarzani et al., 2016).

Research is ongoing on the use of batteries to power vehicles for moving containers horizontally in ports (Chiu et al., 2014). In general, the impact of electrification on emissions and the environment will depend on how and where the electricity is generated. Ports are frequently in windy locations with space available, opening up the possibility of generating electricity in the environmentally friendly ways on site by installing wind turbines or importing and burning biomass. Thus, a spectrum of practical organizational and supply chain arise for the port and maritime transportation greening (Iris and Lam, 2019).

## **5.COMPARISON BETWEEN PRE AND POST GREENING PORTS**

Green ports are related to the long-term strategy for the sustainable development of the port infrastructure in which aims to reduce the greenhouse gas (GHG) emissions (Marzantowicz and Dembińska, 2018). In this section a

comparison is done for the situation of ports and environment between pre and post greening.

First comparison point is related to pollution, the environmental pollution could include both air pollution and water pollution. The air pollution considered harmful emissions into the air (not only by shipping companies, but by any type of transport) (Franchi and Vanelander, 2021). In addition, the water pollution occurs as a result of leaking oil residue from the ships in ports (Deja et al., 2021). This kinds of pollution occurs in the traditional ports, while the greening ports aims to minimize the water and air pollution for the aim of sustainability (Gibbs et al., 2014).

Second point is related to costs; ports and the city are borne very high costs in the traditional ports as a result of ports' detrimental environmental impact. On other hand, the environmentally friendly initiatives and green ports have crucial roles in mitigating the negative footprint of ports on the environment and require a multi aspect and long-term sustainable approach to environmental issues. Such measures would lower external costs (Żukowska, 2020).

Another point of comparison is that green ports work on making balance between the economic demand and the environmental responsibility, while the traditional ports put their main focus on the economic demands (Franchi and Vanelander, 2021).

Accordingly, converting the traditional ports to green one is much better to the environment, in which help in reaching sustainability as well as decreasing the costs. Finally it is important to refer that there are numerous challenges to overcome when attempting to become a green or sustainable port. The environmental, economic, and social challenges that ports face include, in particular, an increase in maritime traffic volumes, an increase in ship size, the cost of upgrading port capacity, volatile energy prices, the transition to alternative fuels, and limits sulphur emission (Franchi and Vanelander, 2021).

Many ports over the world starts to convert into greening, for example; Hamad Port in Qatar. According to the Ministry of Transport and Communications (MoTC) in Qatar, Hamad Port

is considered the largest eco-friendly project in the region, which is internationally recognized as one of the largest green ports in the world. During the Seatrade Marine Awards Middle East, Indian Subcontinent, and Africa 2016, the Hamad Port Project was named the largest smart and eco-friendly project. All of the port's structures, buildings, and equipment are environmentally friendly. Furthermore, for the project, over 12,000 coral pieces were moved and resettled, as well as over 14,000 square meters of coral reefs. Programs were also put in place to enrich the area with nearly 32,000 mangroves and seedlings in order to provide the food and environment needed for marine life to thrive. As a result, the port was named one of the world's greenest in June 2019.

The positive results of converting to greening in Hamad Port has been appeared in 2021, as the port had gained a gateway to the world and succeeded in achieving an increment of containers witnessed over 9% compared to 2020. Moreover, the port has also registered an increase in arrival of vessels in 2021 as 1,750 vessels called on Hamad Port compared to 1,600 in 2020. Hamad Port is expected to have the capacity to handle 7.5 million TEUs at its three terminals on completion of the development stages and greening transferring.

## 6. RESEARCH METHODOLOGY

This study aims to examine the performance of ports before and after applying the green port operations. While, the main operations of green port consisted of (Environmental Quality, Use of Energy and Resources, Waste Handling, Habitat Quality and Greenery and Social Participation)

The target population is defined according to the data collection method used. In addition, the study followed a non-random technique of convenience of sampling for the questionnaire designed as it easy to access; a probability sampling method, of experts to be able to generalize research results. In addition, a sample size of 385 seafarer was used in the study to achieve a confidence level of 95%, with respondents' ratio of 77% as the questionnaires were distributed to the sample of 500 seafarers but only 385 of them were returned and accepted.

The operations used in this study can be

categorized into five main operations, which are; Environmental Quality, Use of Energy and Resources, Waste Handling, Habitat Quality and Greenery and Social Participation.

**Environmental Quality:** Water Pollution, Air Pollution, Noise Pollution, Land, and sediments Pollution.

**Use of Energy and Resources:** Resources (Materials Selection, Water consumption and Energy Usage).

**Waste Handling:** General Waste Handling and Hazardous Waste Handling.

**Habitat Quality and Greenery:** Habitat Quality and Port Greenery.

**Social Participation:** Community promotion and education, and Port staff training.

Figure 1, represents the proposed study model for this research, where the study aimed at the variables

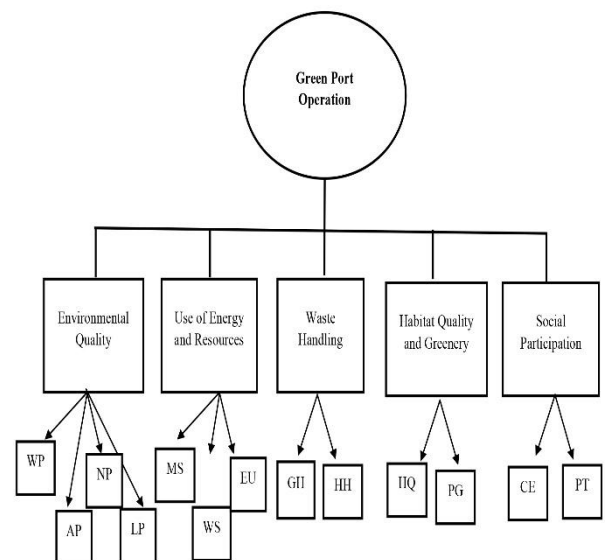

*Figure 1: Research Framework*

**Table 1: Research Variable Operationalization**

<b>Variables</b>	<b>Measurements</b>	<b>References</b>
Environmental Quality (Water Pollution) [WP]	Dredge monitoring and assessment.	Chiu et al., (2014)
	Investigate sewage source.	
	Monitor water quality.	
	Handle spill oil emergency.	
	Install palisade on sewage pipe.	
	Manage ballast water.	
	Handle on board sewage.	
Environmental Quality (Air Pollution) [AP]	Improve the standard of ship's sanitation equipment.	Chiu et al., (2014)
	Set up air quality monitoring system.	
	Set up sulfur and nitrogen emissions control area.	
	Provide shore power.	
	Use energy from renewable sources.	
	Use more electric machines/equipment.	
	Use automated gateway system.	
	Install air filter on port machines.	
	Port machines use clean fuel with lower sulfur content.	
	Monitor dust levels.	
	Implement dust and smoke recycle measures.	
	Monitor smoke from vessels.	
	Adjust the type of importing bulk cargo (e.g., replace coal splinter with block coal).	
	Promote environment-friendly transport.	
	Promote port ride share or use shuttle bus.	
	Establish the carbon footprint.	
	Vessel speed reduction in port.	
Idle control on vehicles and cargo handling equipment.		
Idle truck parking arrangement.		
Use lower air pollution truck.		
Replace or improve the old vehicles.		
Vehicles and vessels to use clean fuel with lower sulfur content.		
Environmental Quality (Noise Pollution) [NP]	Set high standards of noise limits.	Chiu et al., (2014)
	Monitor noise levels during construction and operation.	
	Require to use lower noise.	
	Install double insulation windows and boards.	
	Use noise reduction machines (forklifts, ships, trucks, and other devices vehicles).	

<b>Variables</b>	<b>Measurements</b>	<b>References</b>
Environmental Quality (Land and sediments Pollution) [LP]	Remediation of contaminated sites.	Chiu et al., (2014)
	Reuse of dredge sediments.	
	Sediments deposited in the separated area.	
Use of energy and resource (Materials selection) [MS]	Adopt LEED standard for green building.	Chiu et al., (2014)
	Procure locally available materials and suppliers.	
	Use reusable materials for building/facility.	
	Encourage using environment-friendly materials.	
	Port landscaping to use local native species.	
Use of energy and resource (Water consumption) [WS]	Reduce waste of drinking water and irrigation.	Chiu et al., (2014)
	Monitor water usage and leakage.	
	On-site water treatment and reuse.	
Use of energy and resource (Energy Usage) [EU]	Use new environment-friendly energy in office and port area (e.g., solar power).	Chiu et al., (2014)
	Microclimate design.	
	Use energy efficient control system.	
	Use “heat stop” paint to coat the refrigerated containers.	
	E-document program.	
Waste Handling (General Waste Handling) [GH]	Use energy efficient light in port area.	Chiu et al., (2014)
	Recycle publications or office waste.	
	Reduce packaging use and choice fewer packaging use supplier.	
	Provide a dedicated storage area for recycling.	
	Reuse the construction waste materials.	
	Garbage classification in port area.	
Waste Handling (Hazardous Waste Handling) [HH]	Vessel waste classification.	Chiu et al., (2014)
	Separate hazardous goods and poisons during construction and operation.	
	Employ licensed contractor to handle hazardous waste.	
Habitat Quality and Greenery (Habitat Quality) [HQ]	Sterilizing and burning of cargoes coming from epidemic area.	Chiu et al., (2014)
	Establish indicators of habitat quality.	
	Ecological monitoring in port area.	
	Establish compensation area or alternative area.	
Habitat Quality (Port Greenery) [PG]	Expansion of tidal areas for habitat restoration.	Chiu et al., (2014)
	Grow flowers or trees in port area.	
	Use biological spectrum lighting.	
	Use nonchemical composition of pesticide and fertilizer.	

<b>Variables</b>	<b>Measurements</b>	<b>References</b>
Social Participation (Community promotion and education) [CE]	Allow public to have port tour.	Chiu et al., (2014)
	Provide job opportunity.	
	Encourage public participating in port planning.	
	Provide green port web site.	
	Promote green port concept for the community.	
Social Participation (Port staff training) [PT]	Public opinion survey.	Chiu et al., (2014)
	Hold green port seminar.	
	Provide green facilities/building guide and training.	
	Implement an accredited Environmental Management System.	
	Provide green port training.	



## 7. SEARCH ANALYSIS AND FINDINGS

The researcher in this section tests the results of the data of the research. First, the study starts with Validity and Reliability Tests. Second, descriptive analysis is used to data. Third, the independent sample t-test.

Data Testing using Validity and Reliability for the Research Variables

In this section, the validity for the statements used to measure the main variable of the research. The main concept of the research is the Green Port Operation, which includes Environmental Quality (Water Pollution, Air Pollution, Noise Pollution and Land and sediments Pollution), Use of Energy and Resources (Materials Selection, Water consumption and Energy Usage), Waste Handling (General Waste Handling and Hazardous Waste Handling), Habitat Quality and Greenery (Habitat Quality and Port Greenery) and Social Participation (Community promotion and education, and Port staff training).

Validity analysis implies the extent to which an instrument measures or estimates what it supposes to quantify effectively and measure correctly. Convergent validity tests the data utilizing factor analysis (multivariate technique), where the average variance extracted for each of the scales was determined and calculated. The average variance extracted (AVE) shows the average community for latent factor, which should be 50% or more. In addition, item reliability can be evaluated by the size of the factor loadings of the measures on their corresponding constructs, which should be at least 0.4 (Bell et al., 2018). On the other hand, reliability analysis refers to the level of consistency of the scale used to measure the specified construct. Cronbach's Alpha, as the most commonly and usually utilized trial test of reliability, was applied. It was demonstrated that 0.7 is a satisfactory reliability coefficient but lower thresholds are sometimes used in the literature (Fuentes-Huerta et al., 2018).

This section tests the validity and reliability of the Environmental Quality; it was measured using four dimensions; Water Pollution, Air Pollution, Noise Pollution and Land and sediments Pollution. Table 2 shows the factor loading of the statements as well as the average variance extracted for the water pollution. It was found that

the factor loadings all statements are greater than 0.4. In addition, the result of AVE is more than 50%, therefore, all construct statements are valid. It is also observed that the Cronbach Alpha is more than 0.7. This means that the constructs statements are reliable to form this construct.

Items	Factor-Loading	AVE	Cronbach's Alpha
WP1	.846	89.891%	.984
WP2	.894		
WP3	.912		
WP4	.896		
WP5	.890		
WP6	.924		
WP7	.916		
WP8	.913		
AP1	.875	89.780%	.994
AP2	.899		
AP3	.909		
AP4	.909		
AP5	.888		
AP6	.905		
AP7	.900		
AP8	.904		
AP9	.892		
AP10	.883		
AP11	.899		
AP12	.880		
AP13	.904		
AP14	.909		
AP15	.890		
AP16	.899		
AP17	.908		
AP18	.901		
AP19	.895		
AP20	.905		
AP21	.900		
NP1	.907	90.863%	.975
NP2	.875		
NP3	.933		
NP4	.903		
NP5	.924		
LP1	.945	94.854%	.973
LP2	.946		
LP3	.954		
MS1	.925	90.921%	.975
MS2	.904		
MS3	.900		
MS4	.892		
MS5	.925		
WS1	.942	93.055%	.963
WS2	.940		
WS3	.910		
EU1	.931	93.399%	.986
EU2	.916		
EU3	.946		
EU4	.939		
EU5	.932		
EU6	.940		
GH1	.882	89.972%	.978
GH2	.892		
GH3	.917		
GH4	.913		

Items	Factor-Loading	AVE	Cronbach's Alpha
GH5	.905		
GH6	.890		
HH1	.936	94.158%	.969
HH2	.940		
HH3	.948		
HQ1	.910	91.351%	.968
HQ2	.918		
HQ3	.913		
HQ4	.912		
PG1	.919	92.968%	.962
PG2	.934		
PG3	.936		
CE1	.894	93.065%	.985
CE2	.935		
CE3	.923		
CE4	.936		
CE5	.947		
CE6	.949		
PT1	.889	92.560%	.973
PT2	.949		
PT3	.917		
PT4	.947		

### Descriptive Analysis for the Respondents Profile

The descriptive statistics is a tool in which it explains and gives a distinct understanding of the features of certain data set, by giving short summaries about the respondents and how the diversification had been applied to select a representative sample for the population under study. In addition, the researcher could be able to identify if there is a gap for improvement in the research variables or not. Data is described here using tables of frequencies, which shows the number and the percentage of respondents sharing in the questionnaire under each category. Table 3 illustrates this by showing the frequencies for the respondent profile .

Regarding Gender, it could be observed from Table 3 that the number of 'Male' respondents (n = 292) is higher than 'Female, with a percentage of 37.9%. Considering Age, it could be noticed that respondents at the age group of '41-60 yrs.' are the most frequently appearing, with a number of 179 respondents and a percentage of 23.2% of the sample under study. Similarly, respondents, which having the master degree are the most frequently appearing than other respondents, with a number of 161 responses and a percentage of 20.9% .

Likewise, respondents with income level of '3000\$-4000\$' (n = 164) are higher than other respondents, with a percentage of 21.3% of the

sample under study. In addition, respondents, which are married (n = 238) are higher than other respondents with a percentage of 30.9%.

Table 3: Descriptive Analysis for Respondents Profile

	Frequency	Percent%	Total
<b>Gender</b>			
Male	292	37.9	385
Female	93	24.2	
<b>Age</b>			
From 18-25	36	4.7	385
From 26-40	170	22.1	
From 41-60	179	23.2	
<b>Education Level</b>			
University Student	34	4.4	385
Bachelor Degree	156	20.3	
Master Degree	161	20.9	
PHD Degree	34	4.4	
<b>Income Level</b>			
Less than 1000\$	24	3.1	385
From 1000\$-2000\$	32	4.2	
From 2000\$-3000\$	58	7.5	
From 3000\$-4000\$	164	21.3	
More than 4000\$	107	13.9	
<b>Marital Status</b>			
Single	93	12.1	385
Married	238	30.9	
Divorced	38	4.9	
Widowed	16	4.2	

### Testing the Main Variable of the Research

In this section, the independent sample t-test for the statements used to measure the main variable of the research. Table 3 illustrates that p-value is equal to 0.000, which means there is a significant difference between green port operations before and after application. It is observed from table 4 that the mean value of water pollution after application is greater than the mean value of water pollution before application, which means that the water pollution performs better after application. The mean value of air pollution after application is greater than the mean value of air pollution before application, which means that the air pollution performs better after application. The mean value of noise pollution after application is greater than the mean value of noise pollution before application, which means that the noise pollution performs better after application. The mean value of Land and sediments Pollution after application is greater than the mean value

of Land and sediments Pollution before application, which means that the Land and sediments Pollution performs better after application. This means that Environmental Quality after application the green port operation is better than before application.

Table 4 illustrates that p-value is equal to 0.000, which means there is a significant difference between green port operations before and after application. It is observed from table 4 that the mean value of materials selection after application is greater than the mean value of materials selection before application, which means that the materials selection performs better after application. The mean value of water consumption after application is greater than the mean value of water consumption before application, which means that the water consumption performs better after application. The mean value of energy usage after application is greater than the mean value of energy usage before application, which means that the energy usage performs better after application. This means that Use of Energy and Resources after application the green port operation is better than before application.

Table 4 illustrates that p-value is equal to 0.000, which means there is a significant difference between green port operations before and after application. It is observed from table 29 that the mean value of general waste handling after application is greater than the mean value of general waste handling before application, which means that the general waste handling performs better after application. The mean value of hazardous waste handling after application is greater than the mean value of hazardous waste handling before application, which means that the hazardous waste handling performs better after application. This means that Waste Handling after application the green port operation is better than before application.

Table 4 illustrates that p-value is equal to 0.000, which means there is a significant difference between green port operations before and after application. It is observed from table 29 that the mean value of habitat quality after application is greater than the mean value of habitat quality before application, which means that the habitat

quality performs better after application. The mean value of port greenery after application is greater than the mean value of port greenery before application, which means that the port greenery performs better after application. This means that Habitat Quality and Greenery after application the green port operation is better than before application.

Table 4 illustrates that p-value is equal to 0.000, which means there is a significant difference between green port operations before and after application. It is observed from table 28 that the mean value of community promotion and education after application is greater than the mean value of community promotion and education before application, which means that the community promotion and education performs better after application. The mean value of port staff training after application is greater than the mean value of port staff training before application, which means that the port staff training performs better after application. This means that Social Participation after application the green port operation is better than before application.

Table 4: Independent Sample T-Test for the Research Variable

	Grouping Variable	N	Mean	Sig (2-tailed)
WP	1.00 (Before)	385	1.8312	0.000
	2.00 (After)	385	4.3792	
AP	1.00 (Before)	385	1.7506	0.000
	2.00 (After)	385	4.2805	
NP	1.00 (Before)	385	1.7143	0.000
	2.00 (After)	385	4.2753	
LP	1.00 (Before)	385	1.6494	0.000
	2.00 (After)	385	4.2052	
MS	1.00 (Before)	385	1.6935	0.000
	2.00 (After)	385	4.2831	
WS	1.00 (Before)	385	1.8416	0.000
	2.00 (After)	385	4.3273	
EU	1.00 (Before)	385	1.6753	0.000
	2.00 (After)	385	4.3818	
GH	1.00 (Before)	385	1.8883	0.000
	2.00 (After)	385	4.3818	
HH	1.00 (Before)	385	1.6390	0.000
	2.00 (After)	385	4.2104	
HQ	1.00 (Before)	385	1.8779	0.000
	2.00 (After)	385	4.4909	
PG	1.00 (Before)	385	1.7039	0.000
	2.00 (After)	385	4.2468	
CE	1.00 (Before)	385	1.8649	0.000
	2.00 (After)	385	4.3922	
PT	1.00 (Before)	385	1.8909	0.000
	2.00 (After)	385	4.4078	

## 8. CONCLUSIONS, RECOMMENDATION AND LIMITATION

This study aims to test the performance of ports before and after the application of green port. To test this goal, the researcher used the classical philosophy in this study and the inductive approach because they are more compatible with the nature of the research and with what the researcher wants to reach. Consequently, the data required to test the goal of the study was collected through the quantitative data issued from the questionnaire that was distributed to collect the required data from seafarers. Statistical method such as: independent sample t-test had been used. Each of the measures of validity and reliability are also used, and the truthfulness and reliability of the data are intended as two important conditions that must be fulfilled and available to start using the available data to respond to the research hypotheses.

The recommendations of the current research are that the research should focus on other operations that affect the performance of green port. Future research will be able to have a better timeframe to be able to collect a larger sample as well as follow the technique of random sampling. More future research is needed to explore the effect of applying the green port on ports performance .

This research has several limitations through the study that I covered. First, the time limit to finish the research, which was a hindrance to collecting a larger sample size to represent the data under study. The second limitation was the small number of sample size used in the questionnaires collected, which pushed them to the blanket count method.

## REFERENCES

<https://unctad.org/system/files/official-document/>

<https://www.hellenicshippingnews.com/qatar-hamad>

projects/#:~:text=Qatar's%20gateway%20to%20world,green%20ports%20in%20the%20world

<https://www.hellenicshippingnews.com/hamad-port>

Aregall, M.G., Bergqvist, R. and Monios, J., 2018. A global review of the hinterland dimension of green port strategies. *Transportation Research Part D: Transport and Environment*, 59, pp.23-34.

Barnes-Dabban, H., 2018. Greening African ports: environmental governance transformations in a network society (Doctoral dissertation, Wageningen University and Research).

Bergqvist, R. and Monios, J., 2019. Green ports in theory and practice. In *Green ports* (pp. 1-17). Elsevier.

Chiu, R.H., Lin, L.H. and Ting, S.C., 2014. Evaluation of green port factors and performance: a fuzzy AHP analysis. *Mathematical problems in engineering*, 2014.

Clemens, B. and Douglas, T.J., 2006. Does coercion drive firms to adopt 'voluntary' green initiatives? Relationships among coercion, superior firm resources, and voluntary green initiatives. *Journal of business research*, 59(4), pp.483-491.

Davarzani, H., Fahimnia, B., Bell, M. and Sarkis, J., 2016. Greening ports and maritime logistics: A review. *Transportation Research Part D: Transport and Environment*, 48, pp.473-487.

Defilippi, E. and Flor, L., 2008. Regulation in a context of limited competition: A port case. *Transportation Research Part A: Policy and Practice*, 42(5), pp.762-773.

Deja, A., Ulewicz, R. and Kyrychenko, Y., 2021. Analysis and assessment of environmental threats in maritime transport. *Transportation Research Procedia*, 55, pp.1073-1080.

Dellink, R., Hwang, H., Lanzi, E. and Chateau, J., 2017. International trade consequences of climate change.

- Desrosiers, C., Leflaive, J., Eulin, A. and Ten-Hage, L., 2013. Bioindicators in marine waters: benthic diatoms as a tool to assess water quality from eutrophic to oligotrophic coastal ecosystems. *Ecological indicators*, 32, pp.25-34.
- Du Plessis, J.N., 2014. Development of a supervisory system for maintaining the performance of remote energy management systems (Doctoral dissertation).
- Dumitrescu, G.C., 2014. Major projects that influence world trade. *Global Economic Observer*, 2(2), p.76.
- Franchi, L. and Vanelander, T., 2021. Port Greening: Discrete Choice Analysis Investigation on Environmental Parameters Affecting Container Shipping Companies' Behaviors. *Sustainability*, 13(13), p.7010.
- Gibbs, D., Rigot-Muller, P., Mangan, J. and Lalwani, C., 2014. The role of sea ports in end-to-end maritime transport chain emissions. *Energy Policy*, 64, pp.337-348.
- Iris, Ç. and Lam, J.S.L., 2019. A review of energy efficiency in ports: Operational strategies, technologies and energy management systems. *Renewable and Sustainable Energy Reviews*, 112, pp.170-182.
- Kusnopranto, H., Taruna, W. and Utomo, S.W., 2017. Health, Safety, Security and Environment (HSSE) Perception at the Ferry Port Terminal: A case study at Merak, Banten Province, Indonesia. *Asian Journal of Applied Sciences*, 5(1).
- Lam, J.S.L. and Notteboom, T., 2014. The greening of ports: a comparison of port management tools used by leading ports in Asia and Europe. *Transport Reviews*, 34(2), pp.169-189.
- Lam, J.S.L., 2016. Strategy of a transshipment hub: the case of port of Singapore. In *Dynamic shipping and port development in the globalized economy* (pp. 12-38). Palgrave Macmillan, London.
- Lawer, E.T., 2019. Transnational networks for the 'greening' of ports: learning from best practice?. *GeoJournal*, pp.1-21.
- Lawer, E.T., 2021. Transnational networks for the 'greening' of ports: learning from best practice?. *GeoJournal*, 86(2), pp.743-763.
- Lee, P.T.W., Hu, Z.H., Lee, S.J., Choi, K.S. and Shin, S.H., 2018. Research trends and agenda on the Belt and Road (B&R) initiative with a focus on maritime transport. *Maritime Policy & Management*, 45(3), pp.282-300.
- Luo, M. and Yip, T.L., 2013. Ports and the environment. *Maritime Policy & Management*, 40(5), pp.401-403.
- Marzantowicz, Ł. and Dembińska, I., 2018. The reasons for the implementation of the concept of green port in sea ports of China. *Logistics and Transport*, 37, pp.121-128.
- Notteboom, T. and Rodrigue, J.P., 2017. Re-assessing port-hinterland relationships in the context of global commodity chains. In *Ports, cities, and global supply chains* (pp. 67-82). Routledge.
- Notteboom, T., 2006. Concession agreements as port governance tools. *Research in Transportation Economics*, 17, pp.437-455.
- Notteboom, T., Verhoeven, P. and Fontanet, M., 2012. Current practices in European ports on the awarding of seaport terminals to private operators: towards an industry good practice guide. *Maritime Policy & Management*, 39(1), pp.107-123.
- Rodrigue, J.P. and Notteboom, T., 2013. Containerized freight distribution in North America and Europe. In *Handbook of Global Logistics* (pp. 219-246). Springer, New York, NY.

Saeed, N. and Larsen, O.I., 2010. An application of cooperative game among container terminals of one port. *European Journal of Operational Research*, 203(2), pp.393-403.

Schipper, C.A., Vreugdenhil, H. and De Jong, M.P.C., 2017. A sustainability assessment of ports and port-city plans: Comparing ambitions with achievements. *Transportation Research Part D: Transport and Environment*, 57, pp.84-111.

Smith, T.W.P., 2012. Technical energy efficiency, its interaction with optimal operating speeds and the implications for the management of shipping's carbon emissions. *Carbon Management*, 3(6), pp.589-600.

Yap, W.Y., Lam, J.S.L. and Cullinane, K., 2011. A theoretical framework for the evaluation of competition between container terminal operators. *The Singapore Economic Review*, 56(04), pp.535-559.

Zis, T., North, R.J., Angeloudis, P., Ochieng, W.Y. and Bell, M.G.H., 2014. Evaluation of cold ironing and speed reduction policies to reduce ship emissions near and at ports. *Maritime Economics & Logistics*, 16(4), pp.371-398.

Żukowska, S., 2020. Concept of green ports. Case study of the seaport in Gdynia. *Prace Komisji Geografii Komunikacji PTG*, 23(3), pp.61-68.

# Tidal Datum Levels Realization based on observed Sea level data analysis in Port Said, Egypt

Prepared by

Ahmed M Khedr 1, Nada M Salama 2, Mohamed M Helmy 3, Hassan A EL-Halawany 1

1. College of Maritime Transport and Technology, Arab Academy for Science, Technology and Maritime Transport.
2. Department of Oceanography, Faculty of Science, Alexandria University, Egypt.
3. Benha University, Faculty of Engineering, Civil Engineering Department, Benha, Qalyubia, Egypt.

## المستخلص:

من الضروري مراجعة وتحديث جميع البيانات والمعلومات الموجودة على الخرائط البحرية وذلك أمر حيوي للغاية للسلطات المسؤولة لاتخاذ القرار السليم، ويعتبر التحديث المستمر للعلاقة بين المستويين المرجعيين الأرضي والمائي ذو أهمية حيوية لعديد من المستخدمين فى الصناعات البحرية. تظهر أهمية تلك العلاقة عند التحدث عن الحركات الأرضية الرأسية والتغير فى مستوى سطح البحر.

الهدف من البحث الحالي هو حساب جميع المستويات المدارية المتعلقة بحركة المد والجزر بميناء بورسعيد والمطل على الساحل المصرى لشرق البحر المتوسط. تم استخدام بيانات كل ساعة عن طريق جهاز يقيس مستوى سطح البحر مثبت بميناء بورسعيد بور فؤاد والذي يشترك مع ميناء بورسعيد فى نفس الحوض المائي وبالتالي ستكون خصائص المستويات المدارية للمد والجزر واحده. تم استخدام حزم من البرامج لتطبيق التحليل التوافقي البسيط للبيانات للحصول على خصائص المد والجزر والتي توضح أن نوع المد والجزر هو نصف يومى فى ميناء بورسعيد وميناء بورسعيد. تم حساب المستويات المدارية للمد والجزر بالنسبة للمستوى المدرى صفر حسب معايير هيئة المساحة المصرية، لتحقيق أحدث تعريف لكل من المد والجزر الفلكي الأعلى والأدنى المعتمد من قبل المنظمة الهيدروغرافية الدولية.

بعد التحاليل والحساب وجد أن المدى ما بين أعلى مدر فلكي وأقل مدر فلكي هو 0.4 متر، كما أنه يجب إضافة 0.1 متر كهامش للأمان والذي تم تكتيه من قبل هيئة التجنيد والتدريب البحرى الانجليزية. بعد تطبيق التحاليل الاحصائية على البيانات وجد أنه أعلى مستوى للمياه طبقا للبيانات المرصوده وصل الى 19.012 مترا وأقل مستوى هو 17.318 مترا، لتحقق مدى 1.81 مترا طبقا للمستوى المدرى صفر الذى وضع من قبل هيئة المساحة المصرية. كما وجد أن الفرق ما بين أقل مستوى مدرى من عام 1906 لعام 2015 هو 20 سم وذلك بعد تعريف تم نشره من قبل المنظمة الهيدروغرافية الدولية لأقل مستوى مدرى فى عام 2011. كما يوصى البحث الحالي بتحديث

أعلى وأقل مستوى مدري على الخرائط ليكونا 18.72 و 18.01 مترا على التوالي، وبالتالي تغيير مدى المدر والجزر ليصل 0.5 مترا منسب للمتنسوى المدري صفر من قبل هيئه المساحة المصرية.

## **Abstract:**

A continuous revise and validation for all information on nautical charts is very vital for responsible authorities to take the right decision, especially the guidelines about tidal datum connection with the geodetic vertical datum. This data is needed to be updated continuously as a result of sea-level changes beside tectonic plates movements. The current paper's primary objective is to calculate the tidal levels in Port Said (PS) on Eastern Mediterranean Sea. Hourly sea-level dataset was collected inside Port Foad port, which enclosed with Port Said harbor in the same basin. Harmonic analysis was applied using TIDE tool of Delft-3D hydrodynamic mode. Tidal regime ratio was calculated using Form Factor (FF) equation, indicating 0.21 that expresses semidiurnal tidal domain in the area. Tidal datum levels were realized referred to the Egyptian Surveying Authority (ESA) zero datum, as provided by the Suez Canal Research Institute (SCRI). Furthermore, tidal levels were calculated using MATLAB, fulfilling the most recent definition for both lowest (LAT) and highest (HAT) Astronomical Tides accredited by the International Hydrographic Organization (IHO). Based on the results of analysis and calculations, ranges between highest and lowest same expressions (MHWS & MLWS, MHWN & MLWN, HHWL & LLWL, HAT & LAT) were equivalent to (0.368, 0.096, 0.4372, 0.496 m) respectively. According to the Naval Recruiting and Training Agency (NRTA) a safety margin of ( $\pm 10$  cm) was added to all calculated levels. Moreover, from statistical analysis of observed sea level dataset, it was found that the highest observed water level is (19.128 m), while the lowest recorded water level is (17.318 m), which means a range of (1.81 m) with standard deviation (0.16 m), referred to the (ESA) Zero level. In a nutshell, there is a constant deference in LAT between 1906 - 2015 by 20 cm due to the new definition of LAT level by IHO in 2011, that increased the values. Additionally, HAT and LAT astronomical level values are recommended to be updated in all concerned nautical publications by 18.72 m and 18.01 m respectively, that means astronomical tidal level range equals (0.516 m) referred to the same datum (ESA) zero level.

**Keywords:** Port Foad; Tidal datum; Sea level analysis; Chart Datum



## 1- Introduction

Port Foad is a part of Port Said harbor enclosed in the same water basin as shown in Figure (1-1), which means same tidal pattern and characteristics. Port Said is Egypt's most important harbor located on the northern terminal of the largest international waterway (Suez Canal), and one of the major ports on the Egyptian Mediterranean coast. It is also the main port for Egyptian exports such as cotton and rice, as well as a fueling station for ships passing through the Suez Canal. Port Said is meant to attract logistics startups as well as import and export enterprises due to its excellent geographic location (Encyclopedia Britannica, 2017). It is also considered one of the controllable three harbors on Suez Canal, which is essentially made up of two single-lane waterways that converge at the Great Bitter Lake providing a transit place for ships travelling north and south. The Canal's new expansion, which started in July 2015 included a 72-kilometer stretch of work, now leads to continuous passage of more ships, more than doubling the previous channel's capacity (Biton, 2020).



Figure (1): Port Said harbor illustrated on SC-1 Nautical Chart (INT Chart 7159, 2015)

The determination of tidal datum levels from sea level analysis is of importance for many scientific and socio-economic reasons beside nautical chart production. Long-term fluctuations in sea level are primarily influenced by global, regional and local influences. Furthermore, sea level changes (SLR) are mainly due to global climate change besides, local subsidence or uplift, in addition to, the processes of interaction between ocean and

atmosphere which are the main reasons (Frihy, 2003).

A rise in sea level will necessitate future plans for coastal protection, as well as the possibility of seawater inundation in the future (Woodworth, 1990). According to the IPCC (2013), the global sea level is rising across all oceans, including the Mediterranean Sea area and over the last 100 years, the global sea level has risen by 10 to 25 cm. Furthermore, for vertical land motions, different averaging systems and/or adjustments have been established, resulting in estimates of absolute global MSL rise ranged from 1.0 to 2.4 mm/yr. (Douglas et al., 2001). In 2007, Alam El-din et al., concluded in their study from 3 years of sea level data analysis that; mean seasonal sea level cycle has an amplitude of 15.4 cm, and have had 0.5 cm standard errors, moreover, the results showed a positive MSL trend at Port Said of about 2.87 mm/y. Land- water movement is mainly described by how water levels alter and how much land moves vertically in both space and time (Kenny et al., 2011).

Concerning maritime industry, especially ships in marine navigation and chart production in hydrographic surveying, chart datum levels are very vital and crucial. Additionally, and according to the annual edition of Admiralty Tide Tables (commonly used by all mariners and published by the United Kingdom Hydrographic Office), all known tidal levels (LAT – HAT – MHWS – MLWS – MHWN – MLWN – MSL) were first determined in Egypt at EL-Suez city as a standard port in the area. In 2015, the Egyptian hydrographic department took over the responsibility of producing nautical charts along all the Egyptian waters, with a new International Chart Number (INT.) at the time of the new Suez Canal re- opening. The Egyptian Navy Hydrographic Department (ENHD) started its production by replacing the GB chart covering the canal by two new INT charts (INT7156, INT 7159), replacing the old Admiralty nautical chart (233). This former nautical chart has an old information of tidal levels as shown in Table (1) These tidal level values were calculated by (UKHO) along with the geodetic survey branch of India in 1906, using seven years of observed sea level data at the period from 1897 until 1904

referred to the LAT as the chart datum, which is the same as the zero of the tidal predictions in the area.(UKHONM, 2018).

Table (1): Old tidal datum levels calculated by the Admiralty Hydrographic Office, shown on former admiralty nautical chart No. (233) (UKHO NP203, 2018).

Tidal Levels referred to Datum of Soundings						
Place	Lat N	Long E	Heights in metres above datum			
			MHWS	MHWN	MLWN	MLWS
Port Said (Būr Sa'īd)	31°16'	32°19'	0.6	0.5	0.4	0.3
Suez (As Suways)	29 56	32 33	1.9	1.6	0.7	0.4

For the satisfactory of the newly produced charts, a revise and validation were made for all information on the chart, including tidal datum levels referred to Lowest Astronomical Tide (LAT). The present work aims at studying the sea-level variations for chart tidal datum levels calculations in Port Said harbor .

## 2. Data and Methods of Analysis

### 2.1. Data

Hourly sea level data set acquired from Tide Gauge (T.G) pressure sensor was utilized in this paper. T.G is fixed on the pier inside Port Foad (PF) harbor, at the northern tip of the Suez Canal, at the geographical position (31° 16' N, 32° 19' E) as shown in Figure (2-1). Data is comprised of 44026 records, with 301 missing data tips, which makes it 1846.96 days of data records. Height of tide gauge bench mark is (18.047 m) above ESA zero level as the geodetic datum used to realize sea level measurements in the area, and according to Suez Canal Research Institute (SCRI) documented report. The lowest observed water level at the location of T.G is (17.40 m) above ESA, acquired from historical data analysis of observed sea level, which was measured at the same location using marigraph tide gauge, at the time period from 1980 till 2010. Furthermore, sensor height was adjusted by SCRI to be lower than the lowest observed sea level in the area by fixed value only one meter. In 2010, the old marigraph tide gauge was replaced by a new pressure sensor T.G, for hourly sea level observations.

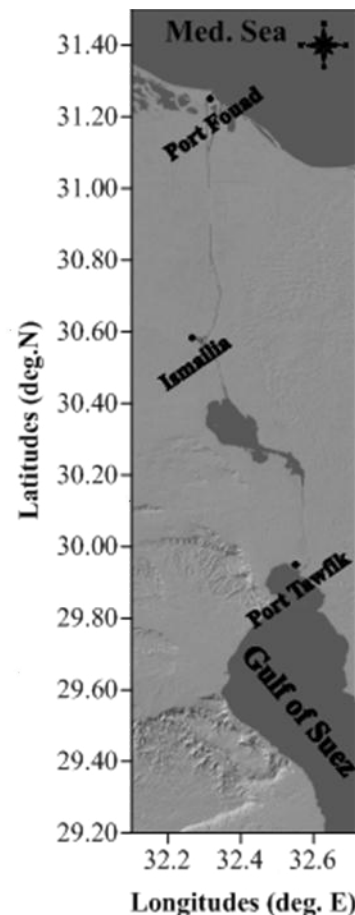

Figure (2): Location of the tide gauge utilized in this investigation in Port Said, Egypt.

### 2.2. Methods of Analysis

#### 2.2.1. Data arranging

Certain fundamental operations were conducted to the sea level data set in this study. All of data was organized and double-checked for errors, anomalies, and spikes then removed from original raw data. Small gaps in the raw time series (one hour) were linearly interpolated, while for large gaps there was only one extended gap for 13 days, and it was converted into (NAN's) values as shown in Figure (2).

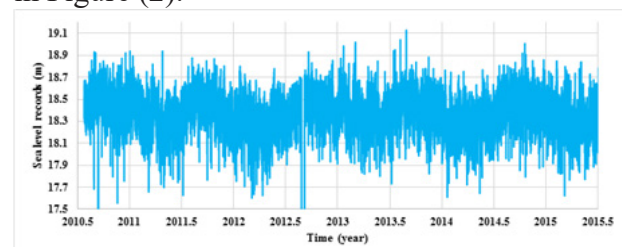

Figure (3): Original observed sea level records in meters, inside Port Foad harbor, (June 2010: July 2015)

### 2.2.2. Data Harmonic analysis

For tidal datum level calculations, separation between tidal and non-tidal signals was done. So, observed sea level data was subjected to harmonic analysis using the TIDE tool in Delft 3D-hydrodynamic model, which applies the following equation (1), (Pawlowicz et. al., 2002);

$$\eta(t) = \sum_n A_n \cos\left(\frac{2\pi}{T_n}t + \varphi_n\right) \quad (1)$$

Where  $\eta(t)$  is the vertical displacement of the sea surface as a function of time (m),  $A_n$  is the amplitude of harmonic component (m),  $T_n$  is the period of harmonic component (s) and  $\varphi_n$  is the phase of the harmonic component.

### 2.2.3. Tidal datum calculations

In the present work, the most known vertical tidal datum levels used on nautical charts such as; HAT, LAT, MHWS, MLWS, MHWN, MLWN, HHWL and LLWL, were obtained after harmonic analysis of observed sea level data, then were revised and updated referred to the ESA geodetic vertical datum in (PF) harbor, according to the SCRI report in 2015. Datum levels were calculated based on the amplitude values of the four majors' constituents (M2, S2, K1, O1) acquired from harmonic analysis and based on the following theoretical formulas (Doodson, 1957).

$$\text{Mean High Water Spring (MHWS)} = \text{MSL} + (\text{M2} + \text{S2}) \quad (1)$$

$$\text{Mean Low Water Spring (MLWS)} = \text{MSL} - (\text{M2} + \text{S2}) \quad (2)$$

$$\text{Mean High Water Neaps (MHWN)} = \text{MSL} + (\text{M2} - \text{S2}) \quad (3)$$

$$\text{Mean low Water Neaps (MLWN)} = \text{MSL} - (\text{M2} - \text{S2}) \quad (4)$$

$$\text{Highest High-Water Level (HHWL)} = \text{MSL} + (\text{M2} + \text{S2} + \text{K1} + \text{O1}) \quad (5)$$

$$\text{Lowest Low Water Level (LLWL)} = \text{MSL} - (\text{M2} + \text{S2} + \text{K1} + \text{O1}) \quad (6)$$

$$\text{Lowest Astronomical Tide (LAT)} = \text{P.F Tide gauge zero level (TGZL)} + \text{MSL} - \text{Absolute Minimum Tidal level} - \text{Absolute Average residuals} \quad (7)$$

$$\text{Highest Astronomical Tide (HAT)} = \text{P.F Tide gauge zero level (TGZL)} + \text{MSL} + \text{Absolute Minimum Tidal level} + \text{Absolute Average residuals} \quad (8)$$

Where MSL is the mean sea level, O1 is the primary lunar diurnal constituent's tidal height, K1 is the luni-solar diurnal constituent's tidal height, M2 is the primary lunar semidiurnal constituent tidal height, and S2 is the major solar semidiurnal constituent's tidal height. According to NRTA a value of + 10 cm will be added as a safety margin.

### 2.2.4. Statistical analysis

A quantitative measure has been made to describe original data signal individually. A descriptive statistics for annually sea level records were calculated using a MATLAB function, for calculating the means, standard deviation, sample variance, minimum and maximum expressed in meters.

## 3. Results

### 3.1. Hourly Recorded Sea Level:

The mean value of the hourly observed sea level data set (18.37 m), this value was subtracted (mean removal) from observed data at Port Foad harbor, in the time period from June 2010 to July 2015, as shown in Figure (4). Hourly sea-level records ranged from 17.55 m on June 2010, to 18.316 m on July, 2015., indicating a maximum range of 1.687 m between recorded minimum and maximum values during this period.

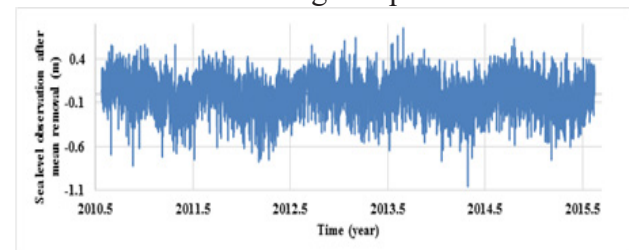

Figure (4): Time series of recorded sea level data set after the mean removal value (18.37).

### 3.2. Harmonic analysis:

From harmonic analysis, the tide program algorithm identified amplitudes of 69 tidal components, with only 38 significant constituents labelled with (“\*”). Amplitudes of

significant constituents changed between 0.35 m to -0.37 m referring to range of a tidal range of 0.72 m. Moreover, based on the outputs of the tidal ratio from form factor (0.21), which reflects semi diurnal tidal domain. According to the amplitude values of the major principal diurnal and semi diurnal constituents' tidal datum values were calculated. The three figures below represent the time series of observed sea level components; sea level (Blue), tidal signal (green), and residual signal (red).

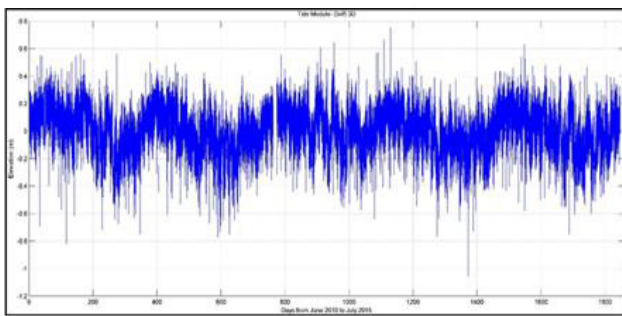

Figure (5): Sea level time series resultant from harmonic analysis by Delft 3D- tide tool.

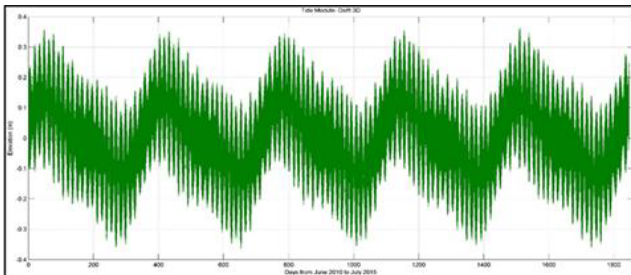

Figure (6): Tidal signal resultant from harmonic analysis by Delft 3D- tide tool.

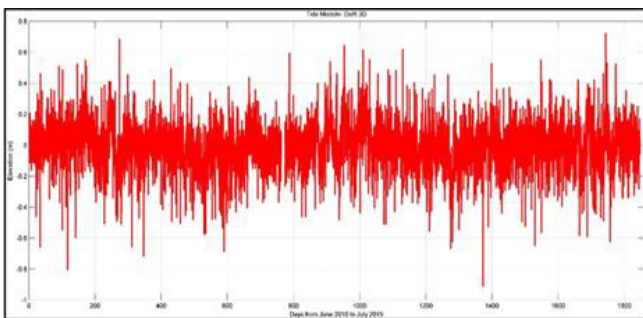

Figure (7): Residual signal resultant from harmonic analysis by Delft 3D- tide tool.

From harmonic analysis tidal constituents' frequencies, amplitudes, and phase angles are represented in Table (2) below.

Table (2): Tidal constituents' frequencies, amplitudes, and phase angles resulted from harmonic analysis.

Frequency (cycle/hr.)	tide	A (m)	Φ (°)	Frequency (cycle/hr.)	tide	A (m)	Φ (°)	Frequency (cycle/hr.)	tide	A (m)	Φ (°)
0.00011	*SA	0.1042	240	0.04329	*J1	0.0017	299	0.11924	*MO3	0.0009	191
0.00023	*SSA	0.0351	244	0.0446	SO1	0.0004	351	0.12077	*M3	0.0034	71
0.00131	MSM	0.0088	247	0.04483	OO1	0.0003	274	0.12206	*SO3	0.0008	171
0.00151	*MM	0.0137	223	0.04634	UPS	0.0006	142	0.12229	*MK3	0.0009	106
0.00282	MSF	0.0061	259	0.07597	*OQ2	0.001	130	0.12511	*SK3	0.0014	358
0.00305	MF	0.0053	78	0.07618	*EPS	0.0012	297	0.15951	MN4	0.0003	21
0.0344	ALP	0.0002	277	0.07749	*2N2	0.0025	312	0.16102	*M4	0.0012	63
0.03571	2Q1	0.0003	199	0.07769	*MU2	0.0031	318	0.16233	SN4	0.0007	43
0.03591	SIG	0.0004	270	0.079	*N2	0.0185	300	0.16384	*MS4	0.0015	115
0.03722	*Q1	0.0019	259	0.0792	*NU2	0.0037	296	0.16407	MK4	0.0003	338
0.03742	RHO	0.0006	300	0.08031	GAM	0.0003	325	0.16667	S4	0.0001	248
0.03873	*O1	0.0166	271	0.0804	HI	0.0003	293	0.16689	SK4	0.0007	154
0.03896	TAU	0.0006	318	0.08051	*M2	0.1124	296	0.2028	2MK	0.0006	200
0.04004	BET	0.0005	15	0.08063	*H2	0.0012	293	0.20845	2SK	0.0002	4
0.04027	*NO1	0.0026	284	0.08074	MKS	0.0005	50	0.24002	*2MN	0.0017	53
0.04047	CHI	0.0004	17	0.08182	*LDA	0.0015	330	0.24153	*M6	0.0018	98
0.04144	*P11	0.0018	246	0.08202	*L2	0.0037	300	0.24436	*2MS	0.0033	149
0.04155	*P1	0.0071	306	0.08322	*T2	0.0041	324	0.24458	2MK	0.0008	154
0.04167	*S1	0.0139	302	0.08333	*S2	0.0686	309	0.24718	*2SM	0.0019	215
0.04178	*K1	0.0215	299	0.08345	R2	0.0006	87	0.24741	MSK	0.0001	23
0.04189	*PS1	0.0009	164	0.08356	*K2	0.0187	331	0.28331	3MK	0.0004	195
0.04201	PHI	0.0006	18	0.08485	*MSN	0.0008	241	0.32205	M8	0.0005	15
0.04309	THE	0.0006	290	0.08507	*ETA	0.0017	319	0.40256	M10	0.0007	206

It seems from the table, that M2, SA and S2 dominated the constituents in amplitude by 11.2 cm, 10 cm and 6 cm respectively, which reflects semi-diurnal regime besides, the dominance of seasonal changes in the area.

### 3.3. Tidal datum levels calculations

As mentioned earlier that datum levels were calculated based on the amplitude values of the four major harmonic constituents (M2, S2, K1, O1) acquired from harmonic analysis. In addition to the ellipsoidal height of the mean sea level value as calculated from original observed sea level dataset referred to ESA geodetic datum, as shown in Table (3).

Table (3): Tidal datum levels referred to the ESA- zero level.

Tidal Datum	Port Foad	NRTA ( $\pm 10$ )
Highest High-Water Level (HHWL; m)	18.59	18.69
Lowest Low Water Level (LLWL; m)	18.16	18.06
Highest water range (m)	0.437	0.637
Mean High Water Spring (MHWS; m)	18.55	18.65
Mean Low Water Spring (MLWS; m)	18.19	18.09
Mean Spring Range (m)	0.36	0.56
Mean High Water Neap (MHWN; m)	18.41	18.51
Mean Low Water Neap (MLWN; m)	18.33	18.23
Mean Neap Range (m)	0.09	0.29
Lowest astronomical tide (LAT; m)	18.12	18.02
Highest astronomical tide (HAT; m)	18.62	18.72
Astronomical tide range (m)	0.50	0.7

According to the Naval Recruiting and Training Agency, + 10 cm value was added algebraically as a safety margin to all tidal datum levels in the table above. For the purpose of correcting and updating the tidal datum levels information shown on the new Suez Canal charts (INT charts, 7156,7159) datum levels were calculated referred to the LAT as shown in Table (4).

Table (4): New updated tidal datum levels calculated from observed sea level data analysis in the period from 2010 to 2015 referred to the LAT.

Places	MHWS	MHWN	MSL	MLWN	MLWS
Port Foad (2015)	0.4	0.3	0.25	0.2	0.1
Old datum values (1906)	0.6	0.5	-	0.4	0.3

From Table (4), it is clear that tidal datum levels differed from old values by almost a constant value 0.2 m, indicating a difference between the datasets referred to the reference level (LAT), can be justified either by methods of analysis and definition of LAT used in 1906 or a constant change in the reference level by 20 cm during the period (109 year). In a nutshell, there is a constant deference in LAT by 20 cm due to the new definition of LAT level by IHO in 2011, that increased the values.

### 3.4. Statistical analysis

A descriptive statistical analysis was applied for the annually records, to clarify difference in sea level change each year.

Table (5): Descriptive statistics of the sea level records during (June 2010 to July 2015) for each year.

Month	Mean (m)	Standard Deviation	Sample Variance	Range (m)	Minimum (m)	Maximum (m)
June -2010	18.47965	0.127398	0.01623	1.383	17.555	18.938
2011	18.35237	0.167242	0.02797	1.309	17.626	18.935
2012	18.37006	0.164074	0.02692	1.381	17.603	18.984
2013	18.383	0.156627	0.024532	1.519	17.609	19.128
2014	18.36653	0.158832	0.025227	1.687	17.318	19.005
July- 2015	18.31674	0.163687	0.026794	1.224	17.623	18.847

It is clear that the maximum water level during the period of investigation was in 2013, while the lowest water level was during 2010. The maximum mean sea level was during 2015, and the maximum and minimum water level range were during 2014 and 2015 respectively.

## 4. Discussion and Conclusions:

Based on the comprehensive analysis of vertical datum levels, it was concluded that:

Tidal vertical datum level calculated from observed sea level data analysis, in Port Foad harbor are as follow; the lowest LAT and the highest HAT values for chart datum and chart heights are (18.12 m) and (18.62 m) respectively, referred to the ESA. Meanwhile, the other tidal datum levels are 0.43, 0.3, 0.2 and 0.065 as the suggested MHWS, MHWN, MLWN and MLWS respectively. A safety margin value ( $\pm 10$  cm) should be considered and added to all calculated final vertical datum levels according to (NRTA, 2004). In a nutshell, there is a constant deference in LAT between 1906 - 2015 by 20 cm due to the new definition of LAT level by IHO in 2011, that increased the values. Additionally, HAT and LAT astronomical level values are recommended to be updated in all concerned nautical publications by 18.72 m and 18.01 m respectively, that means astronomical tidal level range equals (0.516 m) referred to the same datum (ESA) zero level.

## 5. Recommendation :

1-A continuous update is needed for tidal vertical datum realizations referred to the latest international terrestrial reference frame. ITRF or any other new geodetic datum. Additional

studies are required for accurate determination and realization of tidal datum levels for at least 18.6 years to account for tidal nodal cycle.

2- An accurate geodetic bench mark is required in the area, to account for subsidence and uplift of land and consequently the absolute sea level. Finally, an offshore observing sensor is required to collect data outside the harbor for future modeling requirements.

## References

- Alam El-Din, K. M., Abdelrahman S.M. and El Meligy M., (2007); "Seasonal and long-term variations of sea level and meteorological conditions along the Egyptian coasts" proceeding of proceeding of the 8th international conference on the Mediterranean coastal environment, med. coast 07, Alexandria, Egypt.
- Biton, E., 2020. Possible implications of sea level changes for species migration through the Suez Canal. *Sci Rep* 10, 21195.  
<https://doi.org/10.1038/s41598-020-78313>  
.1976The Effect of Deepening and Widening the Canal on Tidal Currents (Suez Canal Feasibility Study). Hydraulics Research Station, Report No. EX 731.
- Doodson, A.T., 1957. The analysis and prediction of tides in shallow water. *International Hydrographic Review*, 4 (1): 85-126.
- Douglas, B. C., M. S. Kearney, and Leatherman, S. P. (2001), "Sea Level Rise: History and Consequences", *International Geophysics Series*, Vol. 57, Academic Press, 232 pp.
- Egyptian Environmental Affairs Agency, 2015. Suez Canal Expansion Project, 20p.  
<https://chm.cbd.int/api/v2013/documents/4A27922D31BC-EEFF-7940-B40D6DB706B/attachments/May%202015%20Invasive.pdf>
- Encyclopaedia Britannica (2017); "Alexandria" Online Source  
<http://www.britannica.com/EBchecked/topic>
- Frihy, O.E. (2003). The Nile Delta-Alexandria coast: vulnerability to sea-level rise, consequences and adaptation. *Mitigation and Adaptation Strategies for Global Change*, 8(2), pp.115-138.
- IHO, (2011); "Resolutions of the International Hydrographic Organization Publication M-3", 2nd ed., available at ([www.iho.int](http://www.iho.int), 2011b).
- IPCC, (2013); "The Physical Science Basis Contribution of Working Group I to the Fifth Assessment", *The Climate Change Report of the Intergovernmental Panel on Climate Change* [Stocker, T.F., D. Qin, G.-K. Plattner, M. Tignor, S.K. Allen, J. Boschung, A. Nauels, Y. Xia, V. Bex and P.M. Midgley (eds.)], Cambridge University Press, United Kingdom, and New York, USA.
- Kenny M., Myers E., Xu J., and Gill S., (2011); "V-Datum Issues of Interest, Future Directions", *Vertical Datum Transformation Tool*, (NOAA) National Ocean Service, MD 20910 USA.
- NRTA, (2004); "Tidal Levels and Datums", Admiralty Naval Recruiting and Training Agency, Hydrographic & Meteorological Training Group, Handout No 417, POSR, HM & HMAS Courses.
- Pawlowicz, R., Beardsley, B., Lentz, S., 2002. Classical tidal harmonic analysis including error estimates in MATLAB using T\_TIDE. *Computers & Geosciences* 28, 929–937.  
[https://doi.org/10.1016/S0098-3004\(02\)00013-4](https://doi.org/10.1016/S0098-3004(02)00013-4)
- Suez Canal Authority (SCA), 2021. Canal Characteristics.  
<https://www.suezcanal.gov.eg/English/About>
- UKHONM (2018); "Admiralty Updating Service for Paper Charts Notice to Mariner", United Kingdom Hydrographic Office page.  
<http://www.ukho.gov.uk/AUS>.
- Woodworth, P. L. (1990), "A search for accelerations in records of European mean sea level", *Int. J. Climatology*, 10, 129-143, 1990.

## Foundational Concepts and Application Challenges of the GMP-BoK in light of Seafaring Officers' Perspectives

Hossam Eldin Gadalla 1<sup>a</sup>, Ahmed Mohamed Ismail 2<sup>a</sup>, Ibrahim Tayel Kotb 2<sup>a</sup>

Arab Academy for Science, Technology & Maritime Transport

### المستخلص:

تثير درجة التطور الحالية والمستقبلية لصناعة النقل البحري العالمي العديد من المخاوف بشأن مستوى الكفاءات البحرية الحالي والذي قد لا يلبي إحتياجات الصناعة وتوقعاتها. إستجابة لتلك المخاوف، قام الإتحاد الدولي للجامعات البحرية الدولية (IAMU) بمبادرة جادة لإنشاء برنامج البحار العالمي المحترف (GMP) بهدف سد الفجوة بين ما تطلبه الصناعة وما تقدمه الإتفاقية الدولية لمعايير التدريب وإصدار الشهادات وأعمال النوبة (STCW) في صورتها الحالية. بناءا على ذلك، تواجه مؤسسات التعليم والتدريب البحري تحديا صعبا يتمثل في وضع مسار مناسب يكفل التحول الناجح نحو إستيعاب مفاهيم البرنامج داخل نظام التعليم والتدريب البحري الخاص بها. إنطلاقا من دعم مؤسسات التعليم البحري في التطبيق، يهدف الباحثون في هذه الدراسة مناقشة المفاهيم الأساسية للبرنامج وتحديات التطبيق ذات الصلة، مع التركيز على إبراز وجهات النظر لضباط البحرية التجارية كدارسين محتملين. تم توظيف أسلوب البحث الوصفي التحليلي في الدراسة وتم جمع البيانات من خلال مراجعة الأدبيات ذات الصلة وتحليل نتائج الأستبيان لعدد ٤٠٨ مشارك من ضباط البحرية التجارية. خلصت الدراسة إلى ضرورة إعتبار التعلم المرن نهجا حيويا في خطة مؤسسات التعليم والتدريب البحري لتحقيق أهداف التعلم المرجوة من برنامج GMP و تلبية إحتياجات الدارسين.

**Abstract:**

The recent and foreseeable developments in the maritime industry raise concerns regarding the current level of maritime competencies depicting that it falls well short of the industry's expectations. As a response, the International Association of Maritime Universities (IAMU) has undertaken a serious initiative to establish the Global Maritime Professional-Body of Knowledge (GMP-BoK) to bridge the gap between what is needed and what is produced by the STCW convention. As a result, MET institutions are confronted with the challenging task of establishing an appropriate pathway that would ensure successful adaptation to accommodate the GMP program into their MET system. Driven by the aim of supporting maritime institutions in facilitating the program's implementation, the researchers of this study intended to clarify the foundational concepts of the program and identify relevant application challenges with a particular emphasis on investigating the seafaring officers' perspectives. A descriptive-analytical method of research was employed in the study, and data was collected by reviewing related literature and analyzing the results of an online questionnaire for 408 maritime seafaring officers from the Middle East and African countries. The study's findings illustrated a necessity for MET institutions to consider flexible learning as a vital approach in their plan to acquire the desired GMP learning objectives while meeting the demands of learners.

**Key Words:** MET, GMP-BoK, Seafaring Officers, Maritime Industry challenges.



## 1. Introduction

The continuous development of competent, skilled, and motivated seafarers, across ranks and nationalities is considered an essential driver for the sustainability of the world economy due to their significant contribution to the global supply chain. As per the UN report on the review of maritime transport 2021 (UNCTAD, 2021), seafarers demonstrated a great devotion and professionalism in sustaining the global supply chain and the world trade by facilitating the delivery of food, medicine, fuel, and many other vital supplies. The Maritime Safety Committee of the International Maritime Organization (IMO), during its meeting session MSC (104), October 2021, agreed that seafarers should be recognized as “Key Workers” due to their indispensable role in both the safe operation of the international maritime fleet and the sustainability of the global economy (LR, 2021). To keep supply chains active and global maritime transport operated safely and effectively, Maritime Education and Training (MET) must produce fit-for-purpose skilled seafarers who can cope with the technologies utilized in all aspects of the industry. According to the World Maritime University (WMU) and the International Transport Worker's Federation (ITF) joint report "Transport 2040", highly automated vessels will reduce the demand for traditional seagoing jobs by 22% by the year 2040, while the need for higher value-added, onshore-based jobs, such as remote working operators, maintenance crews, and mobility as service producers, will increase (WMU, 2019).

This necessitates the continuous development of innovative skills and competencies for maritime professionals on ships and ashore. As the international regulator of the maritime industry, the IMO has made many changes to its Standards

of Training, Certification, and Watchkeeping (STCW) Convention and Code, including the 2010 Manila amendments, to keep it updated with recent and foreseeable developments in the industry. According to Ergun Demirel (2020), MET has been modified multiple times to accommodate new capabilities and develop seafaring officers capable of using cutting-edge technology.

Despite this endeavor, the present level of maritime skills is a source of concern since various studies doubt the convention's ability to keep up with the changes in such a rapidly evolving industry. For example, in its annual review report 2020, the International Chamber of Shipping (ICS) wonders if the current IMO STCW regime remains adequate for purpose in the third decade of the twenty-first century, given that many maritime officers who have already achieved STCW certification are still required by shipping companies to undergo additional training and evaluations before being hired. Consequently, the ICS questions whether the convention can meet the future needs of the maritime industry (ICS, 2020).

Given these concerns, the industry's diverse stakeholders demand a MET system that is aligned with the ongoing and future technological changes in order to contribute to the industry's capital productivity where ships, ports, and logistics hubs have become more sophisticated and digitally interacting in real-time. On the other hand, when seafaring officers consider their options for switching to shore-based careers, it's clear that getting an onshore job is challenging and differs across IMO member states due to the flaws in their MET systems since curriculums are built individually in each country and controlled under local jurisdictions rather than the needs of the global maritime industries. This is agreed by the

research project “Mapping of Career Paths in the Maritime Industries” conducted by the Southampton Solent University and supported by the European Commission (EU, 2020). The report findings reveal that the current seafarers’ education and training systems focus mainly on operational and technical competencies with significant shortcomings in soft, administrative, and management skills, including commercial and business management, which is unfit for shore-based jobs.

The objective of the MET system is to respond and adapt in order to deliver the skills and competencies required for a future-ready, competent, motivated, and sufficiently skilled maritime workforce both at sea and ashore. To attain this goal, MET institutions need to keep revising and modifying their MET system to align it with the drastically changing maritime industry needs while also enhancing career opportunities for seafaring officers’ employability post-seagoing career period.

Driven by such need for a reskilling revolution to bridge the gap between what is needed and what is being produced, the IAMU is contributing to a paradigm shift in MET by establishing the (GMP-BoK) initiative, which incorporates a set of educational outcomes beyond the minimum requirements of the STCW Convention. Such an initiative has been undertaken in collaboration with the Nippon Foundation and is designed to ensure that comprehensive academic programs satisfying the industry and other stakeholders are incorporated into the STCW track (IAMU, 2019)

As a result, MET Institutions are encountering the challenging task of comprehending the program prospects and effectively customizing their MET systems to accommodate the GMP program to meet the needs and expectations of all stakeholders, including learners. For this purpose, the objective of this study is to clarify

the prospects of the GMP program and distinguish its foundational concepts and possible implementation challenges with a particular emphasis on the seafarers’ perspectives to determine critical factors influencing their ability to join the GMP program as a lifelong learning path.

Since this study seeks to obtain the perceptions and aspirations of the seafaring officers regarding how the program can be presented, the authors utilized a descriptive-analytical approach with an online survey as a key method for this research. Data gathering was done through literature, and the results of the online questionnaire were collected and analyzed using "Google Forms."

The contribution of this study is that it can form the basis for considerations on how to ease the implementation of the GMP at MET institutions in the Middle East and Africa.

## **2. The GMP-BoK Foundational Concepts for Future Paradigm of MET**

As explained in the IAMU’s report, GMP is intended to meet the envisaged needs of the maritime industry and evolve the educational and career context while catering to the professional development aspirations of individual seafarers. The information has been gathered through a comprehensive survey designed and administered to the membership of IAMU and other stakeholders in the maritime industry (IAMU, 2019).

Lifelong learning is an organizing principle for education policy toward sustainable development goals. In its agenda for Global Sustainable Development Goals "Education 2030", the United Nations Educational, Scientific, and Cultural Organization (UNESCO) indicates that in an increasingly interconnected

and interdependent world, technological advances are bringing new levels of complexity that require transforming the role of formal education from knowledge delivery to the development of critical thinking (UNESCO, 2018).

Recognizing the future transformation of the maritime industry, the GMP-BoK aims to prepare seafaring officers for further education, work, and life by creating a model that enables them to develop a broad range of advanced skills to effectively integrate and participate in the evolving maritime industry and other linked industries. The major goal in this matter is to produce world-class maritime professionals who are adequately prepared to deal with future developments while also exhibiting the appropriate ethical and behavioral norms. As a general approach, the GMP adopts an “outcome-based education,” which, according to Spady, W.G. (1994), is an educational system that designs and organizes curriculum, instruction, and assessment to ensure that students can perform a specific task at the end of their learning experiences.

### 2.1. The GMP BoK Learning Domains

As per IAMU (2019), the specified learning outcomes in the BoK are associated with learning outcome taxonomies in three educational domains of learning; the Cognitive domain (knowledge), the affective domain (attitudes), and the psychomotor domain (skills), covering various levels of achievements related to different GMP tiers as illustrated in Figure (1). This categorization is explained by the “Taxonomy of Learning Domains,” which was first developed by a group of researchers led by Benjamin Bloom between 1956 and 1972, then was revised in 2001.

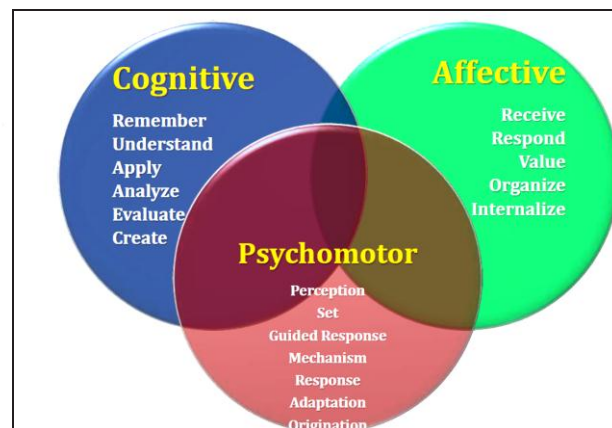

Figure 1: The GMP-BoK Learning Domains  
Source: IAMU, (2019)

According to the GMP BOK criteria, the learning outcomes are categorized into four levels addressed as “Tiers,” where each Tier indicates both the competency level and the academic degree attained by learners and stands as a prerequisite to the next tier, as follows:

- Tier A: COC Operational level + BSc.
- Tier B: COC Management level + BSc.
- Tier C: COC Management level + MSc.
- Tier D: COC Management level + PhD.

### 2.2. The GMP-BoK Focus Areas

The GMP-Bok presents twenty-eight Focus Areas (FA), categorized into four sets of skills as follows:

- 2.2.1. The Foundational knowledge and skills include (6) FAs concerning fundamental art and scientific subjects relevant to a long-term maritime career.
- 2.2.2. The Academic skills; include (4) FAs concerned with research and discovery skills, critical quantitative and qualitative thinking, and academic integrity.
- 2.2.3. The Professional -Technical skills are presented through (7) FAs concerned with technical competencies required to

Carry out professional competencies and tasks.

2.2.4 The Professional - Soft skills; include (11) FAs concerning the skills needed to complement technical skills, mainly where those skills will be expressed in a social context such as in teams. They are primarily knowledge, skills, and attitudes required for optimum socio-technical, human-human, and human organizational interactions.

All are presented in a series of tables and guidelines on how the IAMU-member universities may use the tables. Figure (2) demonstrates the implementation framework with the proposed sequence to navigate the tables of the GMP-BoK. The process, as illustrated, begins with selecting the concerned "Tier" and its related focus areas (FAs), then selecting the corresponding level of achievement (LOA) under each domain, and finally locating the intended learning outcomes (ILOs) for each principle or practice.

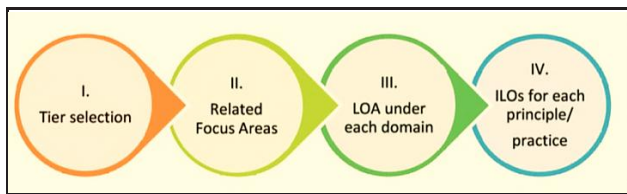

Figure 2: GMP-BoK Implementation Framework  
Source: Source: IAMU, (2019)

### 2.3 Process of Mapping Maritime Safety Programs on the GMP Framework

Maritime safety courses are considered short courses that aim to acquire a specific set of ILOs in compliance with the STCW requirements. Maritime institutions have widely utilized the IMO guiding model courses to determine the ILOs of each course. These model courses and the GMP-BoK adopt outcome-based learning approaches. Such similarity in the methodology facilitates the mapping of maritime safety

programs on the GMP Framework.

However, the proposed sequence of the GMP application framework, as demonstrated in Figure (2), appears to be reversible. The first step should be conducting a gap analysis to assess the extent of each model course's scope to determine possible shortcomings. In this case, starting with locating the ILOs of each level of achievement instead of beginning with the tier selection might be more applicable to attaining the level of achievement as determined by the framework. This is in line with the findings of Graham (2021). He reveals that the BoK's levels of achievement can only be ascertained by drilling down a proposed hierarchical model, where the specific learning outcomes determined by the individual course are on top.

When considering the gap analysis between the course learning outcomes (CLOs) and the GMP ILOs, the following three alternative outcomes might be obtained:

2.3.1. The CLOs cover the GMP ILOs of the corresponding level of achievement.

Many of the skills required for both Tier A and Tier B are covered in the STCW Convention; For example, the Personal Safety and Social Responsibility course incorporates several BoK's skills such as "Human Resource Management," "Technical Awareness," "Leadership," and "Problem-Solving." In this case, simple adjustments to the current model course could be carried out to achieve the desired level of achievement.

2.3.2. The CLOs do not cover the GMP ILOs, but the skill is within the scope of the course., For example, the "Teamwork" skill can be integrated into courses that implicitly include the concept within its contents, such as the Firefighting, Sea Survival, and Survival Crafts courses in proportion to their general context and

educational range.

2.3.3. The CLOs don't cover the GMP ILO, and the skill is not aligned with the course scope, In this case, specific tailor-made course curricula can be developed to demonstrate such skills. It can be designed as an extension to the maritime basics studies or during the qualification periods to obtain and renew COC certificates. This is because the period of any safety course does not exceed five days. Such limited time may not allow for the adequate acquisition of some skills such as "Critical Thinking" and "Creativity," which are considered time-spaced learning and require a longer time frame to be implanted in the learner's mindset.

### **3. Challenges of Implementation from Learners' Perspectives.**

At this stage, the technical prospects of the GMP-BoK appear to be efficient and straightforward for designing the new curriculum, wherein this case, the requirements of the STCW, the GMP, and the industry can be easily met. However, maritime institutions face critical challenges that might influence the functionality of the transition phase, such as reshaping the overall organization behavior and overcoming the resistance to change, preparing the infrastructure/financial capacity, aligning to the national requirements/legislation, and certainly boosting the lecturers' abilities and skills to provide the desired motivating learning environment.

In this regard, the needs and expectations of learners appear to be crucial when delineating the optimum path that assures their satisfaction and motivation. Therefore, the online

questionnaire's purpose was to understand their desires and needs based on their culture and their perception of the labor market needs within their geographical regions.

Recognizing the learner's perspective of the application challenges can give MET institutions another dimension to the whole picture and hopefully contribute to choosing a practical path toward accommodating the GMP. Furthermore, it was also meant to visualize the importance of the topic to the participants and ultimately extend the GMP-Bok awareness among seafaring officers.

### **3.1 Methodology**

An online survey through "Google Forms" generated substantial data from a sample of seafaring officers from 11 countries, including Egypt, Nigeria, Syria, Jordan, Lebanon, Libya, Palestine, Sudan, Comoros, UAE, and Kuwait. This limited the study's results to the Middle East and African regions. Frequency count and percentage were used to report and analyze the numerical data, while thematic analysis was employed in organizing and writing the data from questions. The results presented are based on data collected from seafaring officers who have responded to the survey and a review of relevant literature and studies.

Firstly, the researchers explained the purpose of the study to a convenient sample of deck and engine officers during their enrolment in STCW safety training courses held by the Maritime Safety Institute of the Arab Academy for Science Technology and Maritime Transport (AASTMT) in the period from 5<sup>th</sup> January to 3<sup>rd</sup> April 2022. Participants ranged in age from 20 to 60 years and included both males and females with previous operational and management experience at sea.

The population size was 632 officers, where a

total of (408) or 64.9%, responded to the survey. This can be viewed as a significantly high response rate, as indicated by Dessel (2013), who uncovers that a 20% response rate from the total population size is considered a reasonable rate, while a response rate of 30% can be indicated as a very good ratio in online-based surveys.

Only those respondents who expressed their willingness to participate in the study were invited to receive an explanation regarding the objective and scope of the GMP program before being asked to fill in a questionnaire exploring their perspectives.

The questionnaire consisted of two sections; the first contained respondents' profile information such as age, rank, academic degree, and demographic data, while the second included twelve questions. The first two questions were designed to reveal participants' intention to pursue a higher academic qualification in the following years, as well as their desire to transition to a shore-based job. The questions ranging from 5 to 12 aimed to visualize their perspectives on the challenges that could decrease their chances of joining the program, as well as the possible solutions to overcome them.

## 4. Results and Discussion

### 4.1. Respondents' Profile Information

When examining the respondents' ages, as shown in Table (1), it can be observed that (34.8%) were between the ages of 21 and 30 years, while (50%) were between the ages of 31 and 40 years. This illustrates the younger maritime officers' strong desire to explore future possibilities for advancement and opportunities for continued development.

Table 1: Profile Information

Age	Frequency (n=408)	Percentage
21 to 30	142	34.8%
31 to 40	204	50%
41 to 50	48	11.8%
51 to 60	14	3.4%

Another crucial data collected was the respondents' academic qualifications, which indicated a high ratio of bachelor's degree holders, with (70.4 %) of respondents having achieved a bachelor's degree while attending the AASTMT's College of Maritime Transport and Technology.

### 4.2. The Respondent's Perspectives

#### 4.2.1. The Intentions for Further Education

As shown in Table (2), the first question results demonstrate a significantly high percentage (77.9 %) of seafaring officers aiming for long-term targets and willing to achieve further academic qualifications compared to only (4.2 %) not willing, and (17.9 %) who are still uncertain.

Table 2: Intention to pursue a higher academic qualification.

	Frequency (n=408)	Percentage
Have the intention	318	77.9%
Uncertain	73	17.9%
Not willing	17	4.2%

Furthermore, the results in Table (3) demonstrate that the majority of respondents (80.9%) were interested in joining the GMP program, while (3.2%) disapproved and (15.9%) were undecided.

Table 3: Intention to join the GMP program

	Frequency (n=408)	Percentage
Interested	330	80.9%
Uncertain	65	15.9%
Not willing	13	3.2%

#### 4.2.2 The Desire for a Career Shift

The results of question 3, as shown in Table (4), demonstrate a high rate of respondents (72%) who consider shifting carriers to shore-based jobs, while (25%) rejected the idea and (3%) were uncertain. These results support the GMP objective to prepare seafaring officers for a career transition to shore-based jobs and justify their willingness to join the program.

Table 4: Intention to shift to a shore-based career

	Frequency (n=408)	Percentage
Have the intention	294	72%
Uncertain	12	3%
Not willing	102	2.5%

The results of question 4 revealed the respondents' preferred alternatives to a career at sea, pointing to a variety of shore-based jobs, both in-office and port facilities, such as company management-related positions, Maritime Education, Port Authority, Marine and Technical Surveys, Pilotage, and Harbor services.

It's worth mentioning that a wide variety of maritime-related shore-based sectors were not included in their answers, such as marine insurance, ship agents, maritime law, consultancy, ship and cargo booking, Ship Brokers, and Charterers. Despite the diversity in

their perspectives resulting from their diverse maritime and national cultures, seafaring officers from the studied regions lack a clear vision of their potential job opportunities ashore, necessitating the role of the MET system in mapping and clarifying multiple career paths for their students.

#### 4.2.3. The GMP-BoK Application Challenges

The results of question 5 revealed three major challenges influencing their decision to join the program. As demonstrated in Table (5), "Cost" is at the top of the challenges list, with (41.9%) of respondents referring to the program fees as well as transportation and accommodation expenses. Other respondents (38%) cited "Time" as the main obstacle, whereas (20%) referred to "Geographical Location" as the most challenging difficulty.

Table 5: Challenges influencing the decision to join the GMP program

	Frequency (n=408)	Percentage
Cost	171	41.9%
Time	155	38%
Location	82	20.1%

These findings appear to be consistent with the answers to question 6, in which (43%) of respondents stated that the cost reduction might be a pivotal motivator to join the GMP program. Others (35%) referred to time flexibility, while (22%) cited location flexibility.

#### 4.2.4. The course delivery, educational material, and assessment methods

The responses to questions 7, 8, and 9 are essential considerations for MET institutions when determining the optimal mode of education for interacting with the GMP studies. Table (6) illustrates that "Distance Learning" is the favored

modality for the majority of responders (67.9%). On the other hand, Physical attendance, and the hybrid method, were preferred by (21.1%) and (11%) of respondents, respectively.

Table 6: Respondents' Preferred Mode for Learning

	Frequency (n=408)	Percentage
Distance learning	277	67.9%
Physical attendance	86	21.1%
Hybrid method	45	11.0%

Furthermore, the respondents indicated diverse types of supporting learning materials to be utilized, including view graphs (35%), videos (23%), Books (22%), and simulation (20%). For the assessment purposes, a relatively large ratio of participants (33%) referred to online workshops as a preferable assessment method, whereas others indicated written tests (28%), assignment tasks (24%), and oral exams (15%).

#### 4.2.5. Time Frame and Duration of GMP Studies

In response to questions 10 and 11, most respondents (65%) suggested including tailor-made short courses to deliver the GMP learning outcomes. Furthermore, (78%) of participants indicated that such short courses could be offered during and between their qualifying periods for obtaining their COCs.

#### 4.2.6. Comments

In the findings of question 12, where participants were asked to submit any comments, concerns, and recommendations, several respondents acknowledged their appreciation for being valued by giving importance to their views regarding the program's conception and implementation. Several comments mentioned

the difficulty of being self-sponsored, especially with the low wages problem in some African and Middle East countries.

### 5. The Future Paradigm of MET

The respondents' suggested approach for delivering the GMP program through distance learning appears to be an appropriate choice to tackle the three cited major challenges; cost, time, and geographic location, since accessibility, affordability, and flexibility are some of the primary advantages of e-learning

E-learning is easily accessible and can reach even the most remote regions; also, it is a substantially less expensive mode of education as it doesn't require transportation or accommodation. It also provides learners with a great deal of time flexibility to schedule online classes at their convenience when they are ashore or have internet access onboard their vessels.

This type of learning environment can ensure the GMP-BOK achievement while enhancing students' learning potential by allowing them to learn whenever and wherever they desire, resulting in a process that leads to lifelong learning.

According to Oral & Ergun (2017), e-learning has grown more popular in the maritime education and training field. Several MET institutions offer a wide range of e-learning programs for maritime education, including postgraduate studies. In this setting, MET institutions must also consider staff developing plans for practical training of lecturers to improve their online teaching and relevant technical skills to deliver more effective classes (Chung et al., 2020).

Prospero de Vera III, the chair of the Commission on Higher Education (CHED), anticipated that flexible learning would be the



norm of education over the next few years, with no return to education based solely on face-to-face teaching (Magsambol, 2021).

In line with the global trend toward online education, the IMO Technical Cooperation Division is converting certain current IMO training materials into e-Learning courses to support in-person technical cooperation activities and strengthen the IMO Member States' capacity-building (IMO, 2022).

These findings stipulate the necessity for MET Institutions to demonstrate their ability to deal with the current global paradigm shift toward online education by combining e-learning technologies with advanced Educators' technical capacities to facilitate the implementation of the GMP program in their MET system.

### **Conclusion**

The maritime industry is being transformed by digitalization and automation. Ships, ports, and maritime operations are increasingly becoming more data-driven, which necessitates a need for new competencies at all levels, that can adequately manage such a digitally-enabled industry. Therefore, the MET institution's mission is to evolve its MET systems to build a conducive and motivational learning environment for producing the seafaring officers' needed competencies. In this manner, the IAMU-established GMP-BoK provides an adequate solution for accomplishing this purpose. The primary skill-set relates to a global mindset aware of changing trends with the ability to adapt and evolve via a lifelong learning process. The success in facilitating the implementation of the GMP program will be determined by MET Institutions' efforts to adjust the path of their MET systems to stay on track for generating future industry-ready seafaring officers. The study demonstrated the foundational concepts and provided clear guidance and potential

prospects for implementing the GMP-BoK in the future paradigm of MET. The key findings of the online questionnaire showed that most of the studied sample of seafaring officers were found interested in achieving the GMP program. Such a willingness to pursue further education through academic qualifications is indicative of the new generations of maritime officers' mindsets and their readiness to fit into the future MET paradigm. Bearing in mind that the implications of cost, time, and location are vital factors that affect their decision whether or not to join the program. Based on these findings, Maritime Institutions need to boost their teaching and learning modalities, wherein this concept, establishing an e-learning approach would significantly contribute to achieving the desired GMP learning objectives while satisfying the learners' needs.

### **Recommendations**

- 1- The study recommends establishing technical cooperation among IAMU members to develop flexible and effective learning modalities for the GMP-BoK delivery.
- 2- The study also recommends establishing a practical plan for boosting the maritime lecturer's technical skills to effectively employ the e-learning mode of education.

### **Area for Further research**

Further research is suggested to investigate possible shortcomings in the adequacy of e-learning for delivering the GMP-BoK

## References

- Bates, A.W., (2018). Teaching in a digital age: Guidelines for designing teaching and learning. Tony Bates Associates LTD, Vancouver. ISBN: 978-0-9952692-1-7. Accessed from <https://pressbooks.bccampus.ca/teachinginadigitalagev2>
- Chung, E., Subramanian, G. & Dass, L. C. (2020). Online Learning Readiness among University Students in Malaysia amidst COVID-19. Asian Journal of University Education, 16(2), 46–58. ISSN: ISSN-1823-7797. Accessed from: <https://files.eric.ed.gov/fulltext/EJ1267359.pdf>
- Dessel, G.V., (2013). How to determine the population and survey sample size? Retrieved on 23<sup>rd</sup> Dec.2021 from: <https://www.checkmarket.com/blog/how-to-estimate-your-population-and-survey-sample-size/>
- Ergun Demirel, (2020). Maritime Education and Magsambol, B., (2021). Commission on Higher Education (CHED) chair Prospero de Vera III: There's no going back, "flexible learning will be the new norm." Rappler. Retrieved on 18<sup>th</sup> March 2022, from: <https://www.rappler.com/nation/ched-says-flexible-learning-new-norm/>
- Graham Benton, (2021). The Application of the Global Maritime Professional Framework on a MET Program: A Case Study. Proceeding of the International Association of Maritime Universities (IAMU) Conference AGA 21. Page 177. Alexandria, Egypt. 26 October 2021. Accessed from: <https://aga21.aast.edu/templates/frontend/aga21/ltr/templates/AGA21-Conference-Proceedings.pdf>
- IAMU, (2019). International Association of Maritime Universities (IAMU). (2019). *Global Maritime Professional Body of Knowledge*. Tokyo: International Association of Maritime Universities (IAMU). Accessed from: [https://iamu-edu.org/wp-content/uploads/2019/09/IAMU\\_GMP-Body-of-Knowledge.pdf](https://iamu-edu.org/wp-content/uploads/2019/09/IAMU_GMP-Body-of-Knowledge.pdf)
- IMO, (2022). IMO Website: IMO e-Learning and Training. Retrieved on 18<sup>th</sup> April 2022 from: <https://www.imo.org/en/OurWork/TechnicalCooperation/Pages/IMOe-LEARNING.aspx>
- ICS, (2020). The International Chamber of Shipping (ICS), Annual Review 2020, Page 42. Accessed from: <https://www.ics-shiping.org/wp-content/uploads/2020/11/annual-review-2020-final-compressed.pdf>

- EU, (2020). Study On Social Aspects within the Maritime Transport Sector - Final report. Publications Office of the European Union, 2020: ISBN: 978-92-76-20271-4, Doi: 10.2832/49520. European Union, 2020. Accessed from: <https://oxfordresearch.eu/wp-content/uploads/2021/05/Maritime-transport-sector.pdf>
- Ergun Demirel, (2020). Maritime Education and Magsambol, B., (2021). Commission on Higher Education (CHED) chair Prospero de Vera III: There's no going back, "flexible learning will be the new norm." Rappler. Retrieved on 18<sup>th</sup> March 2022, from: <https://www.rappler.com/nation/ched-says-flexible-learning-new-norm/>
- Oral Erdogan & Ergun Demirel, (2017). New Technologies in Maritime Education and Training, Turkish Experiment. Universal Journal of Educational Research 5(6): 947-952, 2017 <http://www.hrpub.org> DOI: 10.13189/ujer.2017.050606. Accessed from: <https://files.eric.ed.gov/fulltext/EJ1143794.pdf>
- Spady, W.G. (1994). Outcome-Based Education: Critical Issues and Answers. American Association of School Administrators, 1801 North Moore Street, Arlington, VA 22209. Accessed from: <https://files.eric.ed.gov/fulltext/ED380910.pdf>
- LR, (2021). Lloyd's Register Briefing Note – IMO Maritime Safety Committee. One Hundred and Fourth session (MSC 104), Summary Report. 2021. retrieved on 22<sup>nd</sup> December 2021 from: <https://info.lr.org/MSC-104-Summary-Report>
- UNCTAD, (2021). United Nations Conference on Trade and Development (UNCTAD). Review of Maritime Transport 2021. United Nations Publications: UNCTAD/RMT/2021, ISBN: 978-92-1-113026-3, Page 111. Geneva, 2021. Accessed from: [https://unctad.org/system/files/official-document/rmt2021\\_en\\_0.pdf](https://unctad.org/system/files/official-document/rmt2021_en_0.pdf)
- UNESCO, (2018). United Nations Educational, Scientific and Cultural Organization. Sustainable Development Goals. The Global Education Meeting 2018 / 3-5 December 2018. Page 3. Retrieved on 16<sup>th</sup> January 2022 from: [https://en.unesco.org/sites/default/files/2018-12-07\\_brussels\\_declaration.pdf](https://en.unesco.org/sites/default/files/2018-12-07_brussels_declaration.pdf)
- WMU, (2019). World Maritime University, "Transport 2040: Automation, Technology, Employment - The Future of Work" (2019). Reports. 58. <https://commons.wmu.se/libreports/> 58. Accessed from: [https://commons.wmu.se/cgi/viewcontent.cgi?article=1071&context=lib\\_reports](https://commons.wmu.se/cgi/viewcontent.cgi?article=1071&context=lib_reports)

## Effect of Occupancy on Air Outlet Design Alternatives in Ship's Crew Cabins

Khaled Senary<sup>1</sup>, Amman Ali<sup>2</sup>

Arab Academy for Science – Technology & Maritime Transport, Alexandria, Egypt

### المستخلص

عادة ما تكون أماكن الإقامة على متن السفن صغيرة الحجم ، مما يقلل من إمكانية الاختلاط المناسب بين الهواء النقي والهواء الحالي. بالنسبة للسفن ذات الأطقم الكبيرة ، يشغل أربعة من أفراد الطاقم بعض الكبائن ، مما يزيد من الأحمال الحرارية في مثل هذه الأماكن. من أجل الاستخدام السليم لهذه الكبائن عادةً ما يتم استخدام أسرّة بطابقين ، مع ركود الهواء المحبوس بين الأسرة السفلية والعلوية تقريبًا. من ناحية أخرى ، و عادة ما تكون الأسرة العلوية قريبة جدًا من السقف مما يجعل الوضع أسوأ. تم النظر في القياسات الميدانية لمعامل الهواء داخل مقصورة طاقم سفينة حقيقية ومحاكاتها باستخدام برنامج Cfd لدراسه العلاقة بين عدد الركاب ومعاملات التصميم الرئيسية. أظهرت النتائج أنه يمكن الوصول إلى الراحة الحرارية من خلال مزيج مثالي من معايير التصميم الرئيسية. سيتم أخذ العلاقة بين الحمل الحراري ومعاملات التصميم الرئيسية في الاعتبار لدراسة الجدوى المستقبلية

### Abstract

Accommodation spaces onboard ships are normally of small dimensions, which reduce the possibility of proper mixing between fresh and existing air. For ships with large crews, some cabins are occupied by four crew members, which increases heat loads in such spaces. For proper use of these cabins bunk beds are usually used, with the air trapped between lower and upper beds almost stagnant. On the other hand, the upper beds are usually very close to the ceiling which makes the situation even worse. Field measurements of air parameters inside a real ship crew cabin were considered and simulated using a well-known Computerized Fluid Dynamics (CFD) software to study the relationship between number of occupants and main design parameters. Results showed that thermal comfort can be reached through an optimal combination of main design parameters. Correlation between heat load and main design parameters would be taken into consideration for future feasibility study.

Keywords: human factors, crew comfort, indoor air quality.

## 1-INTRODUCTION

Ship volume is directly related to propulsion energy, i.e. engine capital and running costs. That is why ship owners prefer to give the most of the ship size to commercial needs. The Maritime Labor Convention (MLC) which came into force in 20 August 2013 and amended 2016, forces shipbuilders to maintain minimum detailed requirements for accommodation needs. These rules compromise between the ship owners and crew needs (ILO, 2020). Therefore, accommodation area is relatively small, and ceiling height is also low i.e., small air volume within the accommodation spaces. For ships with large crew number, there are rooms inhabited by four crew members, which increases heat load for such cabins. Also, due to the optimal utilization of ship spaces, usually these cabins are provided with two upper and lower level bunk beds, posing areas where the air is almost completely stagnant, such as cabin corners and the spaces between each upper and lower level bunk bed. Additionally, it should be observed that the two upper level beds are always very close to the ceiling of the cabin. Consequently, using the traditional methods of handling the air in ships cabins "where air enters from a distributor located in the center of the cabin ceiling and exists from a register located in the lower part of the cabin door", it is necessary for achieving good air distribution in the space within each upper and lower bunk beds to increase the inlet air speed significantly, which negatively affects the area above the two upper level beds.

## 2- LITERATURE REVIEW

The following section discusses the previous research efforts through available Literature Review. Jinob Chen et al analyzed experimentally and numerically the ship cabin air-conditioning heating characteristics with respect to cabin inlet air velocity and direction through air distribution evaluation index. The study found out the suitability of supply air angle

of ship cabin in high air velocity heating conditions (Chen et al, 2015). Nawaz et al studied thermal comfort in a ship airconditioning system by evaluating the performance of different types of air supply outlets. The researchers have performed Thermal comfort analyses using Simulation software where they could change the number, type and position of air supply outlets and the comfort was optimized by evaluating the values of temperature, velocity, and diffusion percentage. They concluded that air supply outlet is a vital part in any type of (HVAC) Heating ventilation & Air conditioning system design, as its number, type and position has a significant effect on the air distribution and thermal comfort in a subject space (Nawaz et al, 2013). Makhoul A. et al studied room air ventilation patterns experimentally and numerically. They introduced ceiling-mounted personalized ventilation nozzle assisted by small desk-mounted fan. Their comparative study has revealed the advantage of what is called personalized ventilation over the traditional mixing ventilation pattern. The desk-mounted fans were able to reduce the convection plumes around the occupant and improved the performance of the single jet Personalized Ventilation (PV) nozzle by doubling the ventilation effectiveness and improving comfort. They could also achieve a reduced energy saving by up to 13% when compared with conventional mixing ventilation systems (Makhoul et al, 2013).

Makhoul. et al extended their study of room air ventilation patterns experimentally and numerically by introducing an integrated ceiling diffuser and personalized ventilator coaxial nozzle system to localize the air conditioning and fresh air needs around the occupants. The coaxial nozzle minimized air entrainment between the fresh air stream and the room air and allowed effective delivery of clean air. Practical verification was performed with ten human participants who have undergone three different experiments and the survey showed good agreement with the predicted numerical

results. The study has also concluded that localized air conditioning system reduced the energy consumption by up to 34% when compared with conventional mixing systems and would provide the same level of thermal comfort (Makhoul et al, 2013).

Rees. et al set up a test chamber equipped with displacement ventilation and chilled ceiling panel systems. Further, the vertical temperature gradient and air velocities for different experiments were investigated. The results of displacement ventilation were consistent with other studies and linear temperature gradients were found in all cases. In addition, significant mixing, indicated by reduced temperature gradients, was evident in the upper part of the room in the chilled ceiling results at higher levels of heat gain. Visualization experiments, velocity measurements and related numerical studies indicated that with greater heat gains the plumes have sufficient momentum to drive flow across the ceiling surface and down the walls. Furthermore, in cases with moderately high internal gains, comparison of the temperature gradients indicated that the effect of ceiling surface temperature on the degree of mixing and the magnitude of the temperature gradient were of secondary importance. A thorough review of the open literature has revealed lack of research on ship crew cabins air quality, although classification societies concerned with the maritime industry have shown persistent interest, while both American Bureau of Shipping (ABS) and Det Norske Veritas-Germanischer Lloyd (DNV-GL) societies set up a compulsory crew habitability codes to be implemented onboard their certified ships. The codes contain detailed crew thermal comfort in addition to many other comfort ratings. The aim of the paper to determininig effect of ooccupancy on air outlet design alternatives in ships crew cabins. (ABS, 2016) & (DNV-GL, 2017) And to investigate the relationship between heat load and design alternatives for compact cabins, using CFD.

### 3. CASE STUDY

The selected cabin belongs to an existing ship called "Ocean Taba", shown in Fig. (1), serving in Abo-Quir gulf, Alexandria, Egypt, territorial water, in the Mediterranean Sea



Figure(1). Ocean Taba ship, general view.

Air is supplied to each cabin through a duct and a single diffuser and returns to the fan coil unit by means of an exhaust fan extracting the exit air from the cabin door to the hallo ways, as shown in Fig. (2). A typical "Ocean Taba" ship crew cabin was selected to investigate experimentally the airflow pattern and temperature distribution within the cabin. The cabin is 2.85 m width, 4.03 m length and 2.1 m height. The furniture incorporates two bunk beds, one suitcase, one big table, one small table, and a sofa. The cabin incorporates two critical compartments, which are the spaces between upper and lower levels in each bunk bed. Only one wall is insulated, which is the external wall. Air enters the cabin through a 25 cm diameter diffuser placed in the middle of the ceiling, and exits from (43.8 cm wide x 22.5 cm height) register in the middle of the door, 1.5 cm apart from the lower edge of the door, as shown in Fig.( 3).

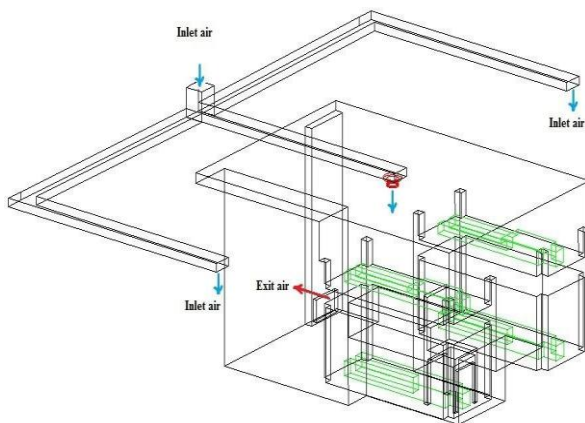

Figure( 2). Air handling ducts to/from selected cabin.

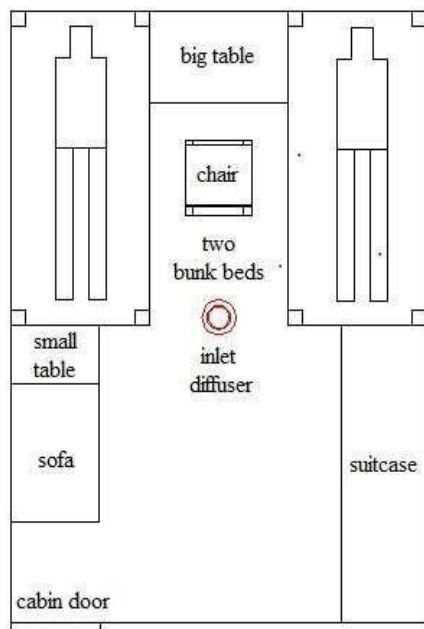

Figure (3). The selected test space.

### 3.1 SURVEY POINTS DEFINITION

In order to assign symmetrical survey points, the x, y and z increments were taken all equal to 0.85 m. Fourteen points were excluded, however, because they were located out of the interior air domain. Table 1 defines the thirty-one survey points, S-1 to S-31, considered at predefined horizontal planes (Z-1 to Z-3); 0.2 m, 1.05 m and 1.9 m above the cabin floor.

Table (1). Survey point coordinates.

Point designation	Coordinates (m)			Point designation	Coordinates (m)		
	x	y	Z		x	y	z
S-1	0.575	0.32	0.2	S-17	1.425	3.72	1.05
S-2	1.425	0.32	0.2	S-18	2.275	3.72	1.05
S-3	1.425	1.17	0.2	S-19	0.575	0.32	1.9
S-4	1.425	2.02	0.2	S-20	1.425	0.32	1.9
S-5	1.425	2.87	0.2	S-21	0.575	1.17	1.9
S-6	0.575	0.32	1.05	S-22	1.425	1.17	1.9
S-7	1.425	0.32	1.05	S-23	0.575	2.02	1.9
S-8	0.575	1.17	1.05	S-24	1.425	2.02	1.9
S-9	1.425	1.17	1.05	S-25	2.275	2.02	1.9
S-10	0.575	2.02	1.05	S-26	0.575	2.87	1.9
S-11	1.425	2.02	1.05	S-27	1.425	2.87	1.9
S-12	2.275	2.02	1.05	S-28	2.275	2.87	1.9
S-13	0.575	2.87	1.05	S-29	0.575	3.72	1.9
S-14	1.425	2.87	1.05	S-30	1.425	3.72	1.9
S-15	2.275	2.87	1.05	S-31	2.275	3.72	1.9
S-16	0.575	3.72	1.05				

### 3.2 EFFECT OF HEAT LOAD

Previous work had been conducted for the selected cabin , modifying air cabin inlets and exits as shown in Fig. (4). A typical proposed diffuser is shown in Fig (5). It is seen to consist of 81 perforations, each of 30 mm diameter and a pitch of 50 mm. As such, the total inlet area per diffuser is 0.057 m<sup>2</sup>.

Based on the performance of design alternatives, the best design was singled out. The potential capabilities and salient features of this best design are further investigated through studying the effect of varying the heat load on Air Diffusion Performance Index (ADPI) which based on acceptance and recongination that it is not possible to achives acomfortable level of 100 percent but 70 percent acceptance and designer should plan to have an ADPIof grater than 80 . The final proposed design was investigated to study the relation between cabin heat load (number of occupants) and the ADPI. While in real situation the number of occupants is subject to change, it is necessary to predict the response of air diffusion performance to the change of number of occupants. In each case of the prediction study the load is reduced by 25% (one occupant). More important still, the study assumes 2 cases, namely a) constant mass flow rate (Pattern 1-1 to Pattern 1-4) and b) variable mass flow rate (Pattern 2-1 to Pattern 2-4) i.e.

reducing the mass flow rate with the reduction of number of occupants.

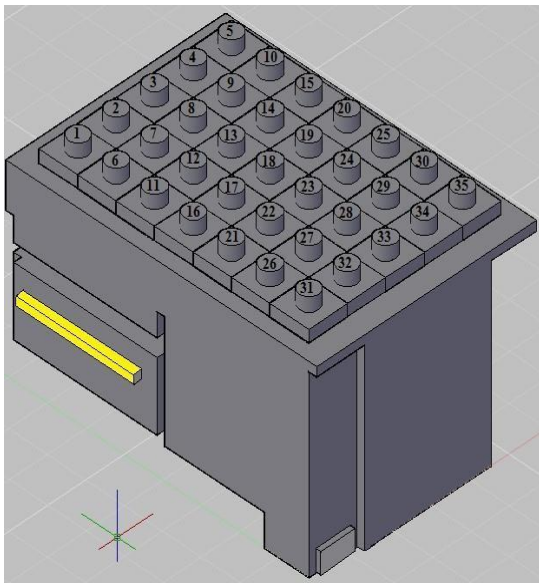

Figure (4). The modified test space.

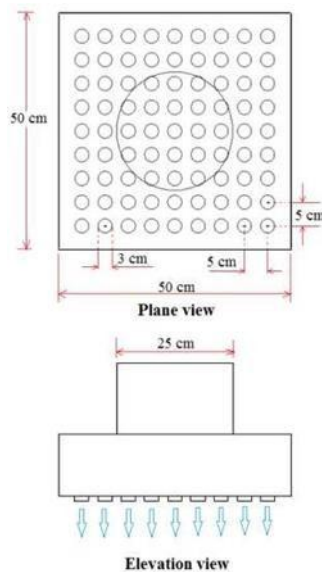

Figure (5). Proposed diffuser details.

### 3.5 DATA REDUCTION

A parameter called the effective draft temperature (EDT), combining the effects of uneven space air temperature and air movement, is often used to assess the deviations of local magnitudes from the mean value,

and is defined as:

$$EDT = T - T_r - a(V - V_{rm}) \quad (1)$$

where  $T$  and  $V$  are space air temperature and velocity, respectively, at a specific location,  $T_r$  is mean space air temperature or set point,  $a$  is a conversion constant to combine the effects of space air temperature and air movements (its value is 8 when  $T$  is expressed in  $^{\circ}\text{C}$  and  $V$  in  $\text{m/s}$  or 0.07 when  $T$  is expressed in  $^{\circ}\text{F}$  and  $V$  in  $\text{fpm}$ ), and  $V_{rm}$  is the desirable mean space air velocity, which is closely related to the space air temperature and could be taken as  $0.15 \text{ m/s}$  ( $29.5 \text{ fpm}$ ).

The air diffusion performance index ADPI in percent, which is used to evaluate the performance of space air diffusion, is calculated as:

$$ADPI = \frac{NEDTX100}{N} \quad (2)$$

where NEDT is number of points measured in occupied zone in which:  $-1.7^{\circ}\text{C} < EDT < +1.1^{\circ}\text{C}$  ( $3^{\circ}\text{F} < EDT < +2^{\circ}\text{F}$ ) and  $N$  is total number of points measured in occupied zone. The higher is the ADPI, the higher the percentage of occupants who feel comfortable will be. Maximum ADPI reaches 90%. In the current study, ADPI is taken to be the main design criterion.

### 4. Results and Discussion

Table (2). lists values of air velocity,  $V$  ( $\text{m/s}$ ) and temperature,  $T$  ( $^{\circ}\text{C}$ ) and EDT ( $^{\circ}\text{C}$ ) as given by the CFD model output for different heat loads, namely: 100%, 75%, 50% and 25% for Pattern 1 cases (constant mass flow rate). Based on the results listed in Table (2), values of ADPI were calculated and are listed in Table (3). It is clear from this table that the ADPI values are almost constant, which is also shown in Figure 6 representing the relation between ADPI and occupancy (%). Similarly, Table (4). lists values of air velocity,  $V$  ( $\text{m/s}$ ) and temperature,  $T$  ( $^{\circ}\text{C}$ )



and EDT (°C) as given by the CFD model output for different heat loads, namely: 100%, 75%, 50% and 25% for Pattern 2 cases (variable mass flow rate). Based on the results listed in Table 4, values of ADPI were calculated and are listed in Table (5). Contrarily to the former pattern (Pattern 1), this pattern (Pattern 2) shows considerable variation of ADPI values with heat load. For instance, by reducing load to 50% a change of 14.3% in ADPI value has been obtained. Further reduction of heat load to 25% resulted in 17.8% ADPI reduction. These results are also depicted in Fig.( 7).

In addition to ADPI criterion verification, EDT distribution Criterion has also been investigated. Fig. (8) illustrates EDT distribution throughout three different layers for the case of varying mass flow rate (Pattern 2). Results show that reducing the heat load, combined with varying the mass flow rate, has resulted in significant discomfort in the three layers, layer Z-3 being the worst. This result is particularly important, because it implies that reducing the heat load does not necessarily mean that the mass flow rate can also be reduced proportionally.

Table (2). Patterns (1) results.

Point designation	Pattern 1-1			Pattern 1-2			Pattern 1-3			Pattern 1-4		
	V (m/s)	T (°C)	EDT (°C)	V (m/s)	T (°C)	EDT (°C)	V (m/s)	T (°C)	EDT (°C)	V (m/s)	T (°C)	EDT (°C)
S-1	0.06	18.07	-0.17	0.06	18.04	-0.20	0.06	18.03	-0.21	0.06	17.98	-0.25
S-2	0.01	18.10	0.27	0.01	18.07	0.24	0.01	18.07	0.23	0.01	18.02	0.19
S-3	0.01	18.04	0.26	0.01	18.00	0.22	0.01	17.99	0.22	0.01	17.94	0.16
S-4	0.01	18.08	0.26	0.01	18.02	0.21	0.01	18.00	0.19	0.01	17.94	0.13
S-5	0.01	18.34	0.52	0.01	18.28	0.46	0.01	18.26	0.44	0.01	18.20	0.38
S-6	0.03	17.96	0.02	0.03	17.93	-0.01	0.03	17.93	-0.02	0.03	17.87	-0.07
S-7	0.01	17.95	0.10	0.01	17.92	0.07	0.01	17.91	0.06	0.01	17.87	0.02
S-8	0.01	17.90	0.04	0.01	17.85	0.00	0.01	17.84	-0.01	0.01	17.77	-0.08
S-9	0.01	17.86	0.02	0.01	17.83	-0.02	0.01	17.82	-0.02	0.01	17.76	-0.08
S-10	0.01	18.10	0.28	0.01	17.93	0.11	0.01	17.92	0.10	0.01	17.83	0.01
S-11	0.02	17.81	-0.07	0.02	17.77	-0.11	0.02	17.75	-0.12	0.02	17.67	-0.21
S-12	0.01	18.17	0.32	0.01	18.14	0.29	0.01	18.07	0.22	0.01	18.01	0.17
S-13	0.03	18.63	0.69	0.03	18.14	0.19	0.03	18.13	0.19	0.03	17.96	0.02
S-14	0.03	17.97	0.00	0.03	17.94	-0.02	0.03	17.93	-0.03	0.03	17.72	-0.25
S-15	0.03	18.35	0.38	0.03	18.32	0.35	0.03	18.15	0.18	0.03	18.02	0.05
S-16	0.02	18.97	1.06	0.02	18.86	0.94	0.02	18.85	0.94	0.02	18.55	0.64
S-17	0.03	18.71	0.73	0.03	18.70	0.72	0.03	18.70	0.72	0.03	18.43	0.45
S-18	0.02	18.96	1.02	0.02	18.95	1.02	0.02	18.91	0.98	0.02	18.75	0.82
S-19	0.01	18.00	0.21	0.01	17.98	0.19	0.01	17.98	0.18	0.01	17.93	0.14
S-20	0.03	17.48	-0.50	0.03	17.47	-0.52	0.03	17.46	-0.52	0.03	17.43	-0.55
S-21	0.01	17.83	0.02	0.01	17.81	-0.01	0.01	17.80	-0.02	0.01	17.73	-0.09
S-22	0.03	17.45	-0.51	0.03	17.43	-0.53	0.03	17.43	-0.53	0.03	17.39	-0.57
S-23	0.03	17.11	-0.87	0.03	17.10	-0.88	0.03	17.09	-0.89	0.03	16.96	-1.02
S-24	0.04	17.04	-0.98	0.04	17.03	-1.00	0.04	17.03	-1.00	0.04	16.98	-1.05
S-25	0.03	16.93	-1.09	0.03	16.93	-1.09	0.03	16.93	-1.09	0.03	16.93	-1.09
S-26	0.01	18.98	1.18	0.01	18.97	1.17	0.01	18.97	1.17	0.01	17.73	-0.06
S-27	0.04	16.91	-1.13	0.04	16.91	-1.13	0.04	16.91	-1.13	0.04	16.83	-1.20
S-28	0.01	18.54	0.71	0.01	18.53	0.71	0.01	18.53	0.71	0.01	18.50	0.68
S-29	0.01	20.86	3.06	0.01	20.85	3.06	0.01	20.85	3.05	0.01	18.90	1.11
S-30	0.05	16.47	-1.67	0.05	16.47	-1.67	0.05	16.47	-1.67	0.05	16.46	-1.67
S-31	0.01	19.83	1.99	0.01	19.83	1.99	0.01	19.83	1.98	0.01	19.81	1.97

Table (3). Summary of Pattern (1) results (Constant mass flow rate).

Pattern	Vi	ADPI	Occupancy (%)
1-1	0.2143	90.3	100%
1-2	0.2143	90.3	75%
1-3	0.2143	90.3	50%
1-4	0.2143	93.5	25%

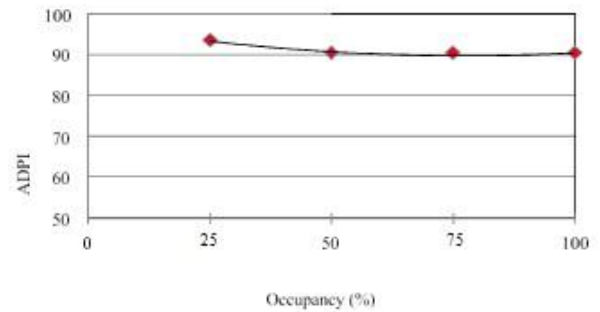

Figure (6). Correlation between ADPI and occupancy percentage for pattern 1.

Table (4). Patterns (2) results

Point designation	Pattern 2-1			Pattern 2-2			Pattern 2-3			Pattern 2-4		
	V (m/s)	T (°C)	EDT (°C)	V (m/s)	T (°C)	EDT (°C)	V (m/s)	T (°C)	EDT (°C)	V (m/s)	T (°C)	EDT (°C)
S-1	0.06	18.07	-0.17	0.05	18.20	0.06	0.04	18.39	0.33	0.03	18.54	0.57
S-2	0.01	18.10	0.27	0.01	18.23	0.41	0.01	18.41	0.61	0.01	18.56	0.78
S-3	0.01	18.04	0.26	0.00	18.17	0.40	0.00	18.36	0.60	0.00	18.52	0.77
S-4	0.01	18.08	0.26	0.01	18.20	0.40	0.01	18.38	0.60	0.00	18.54	0.77
S-5	0.01	18.34	0.52	0.01	18.43	0.63	0.01	18.58	0.79	0.01	18.90	1.12
S-6	0.03	17.96	0.02	0.02	18.11	0.20	0.02	18.31	0.44	0.01	18.49	0.65
S-7	0.01	17.95	0.10	0.01	18.10	0.27	0.01	18.30	0.49	0.01	18.48	0.69
S-8	0.01	17.90	0.04	0.01	18.04	0.21	0.01	18.26	0.45	0.01	18.44	0.65
S-9	0.01	17.86	0.02	0.01	18.02	0.20	0.01	18.24	0.43	0.01	18.43	0.64
S-10	0.01	18.10	0.28	0.01	18.12	0.31	0.01	18.33	0.55	0.00	18.48	0.71
S-11	0.02	17.81	-0.07	0.01	17.98	0.13	0.01	18.21	0.39	0.01	18.40	0.60
S-12	0.01	18.17	0.32	0.01	18.33	0.51	0.01	18.43	0.63	0.01	18.59	0.82
S-13	0.03	18.63	0.69	0.02	18.34	0.44	0.02	18.58	0.71	0.01	18.67	0.84
S-14	0.03	17.97	0.00	0.02	18.18	0.26	0.02	18.48	0.59	0.01	18.59	0.74
S-15	0.03	18.35	0.38	0.02	18.56	0.63	0.02	18.60	0.72	0.01	18.95	1.10
S-16	0.02	18.97	1.06	0.02	19.08	1.19	0.01	19.33	1.48	0.01	19.33	1.51
S-17	0.03	18.71	0.73	0.03	18.98	1.04	0.02	19.33	1.44	0.01	19.46	1.61
S-18	0.02	18.96	1.02	0.02	19.18	1.28	0.02	19.39	1.53	0.01	19.51	1.68
S-19	0.01	18.00	0.21	0.01	18.15	0.37	0.00	18.34	0.57	0.00	18.51	0.75
S-20	0.03	17.48	-0.50	0.03	17.69	-0.24	0.02	17.95	0.06	0.01	18.22	0.37
S-21	0.01	17.83	0.02	0.01	18.00	0.20	0.01	18.23	0.44	0.00	18.40	0.63
S-22	0.03	17.45	-0.51	0.02	17.66	-0.26	0.02	17.93	0.05	0.01	18.20	0.36
S-23	0.03	17.11	-0.87	0.02	17.38	-0.55	0.02	17.73	-0.15	0.01	17.91	0.07
S-24	0.04	17.04	-0.98	0.03	17.29	-0.68	0.02	17.62	-0.30	0.02	17.94	0.07
S-25	0.03	16.93	-1.09	0.03	17.12	-0.84	0.02	17.41	-0.50	0.02	17.81	-0.05
S-26	0.01	18.98	1.18	0.01	19.17	1.38	0.00	19.45	1.68	0.00	18.40	0.64
S-27	0.04	16.91	-1.13	0.03	17.19	-0.79	0.02	17.56	-0.37	0.02	17.87	0.00
S-28	0.01	18.54	0.71	0.01	18.78	0.97	0.01	19.10	1.30	0.01	19.46	1.68
S-29	0.01	20.86	3.06	0.01	21.08	3.29	0.01	21.34	3.57	0.00	19.51	1.75
S-30	0.05	16.47	-1.67	0.04	16.58	-1.47	0.03	16.79	-1.17	0.02	17.21	-0.68
S-31	0.01	19.83	1.99	0.01	20.19	2.37	0.01	20.67	2.87	0.01	21.21	3.42

Table (5). Summary of Pattern (2) results (Variable mass flow rate).

Pattern	Vi	ADPI	Occupancy (%)
2-1	0.2143	90.3	100%
2-2	0.1756	83.9	75%
2-3	0.1368	77.4	50%
2-4	0.0980	74.2	25%

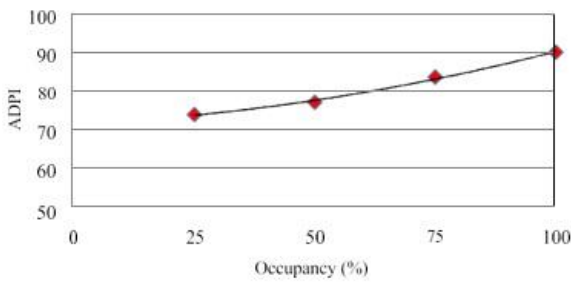

Figure (7). Correlation between ADPI and occupancy percentage for pattern 2.

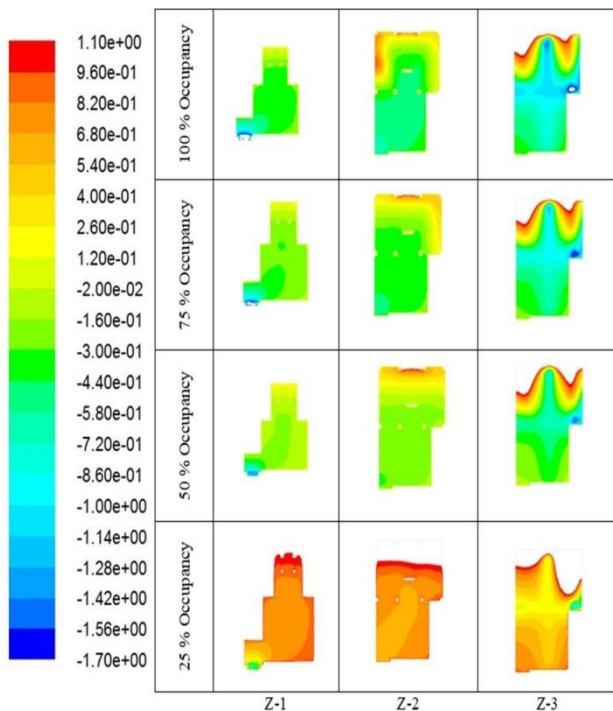

Figure (8). EDT distribution throughout layers Z-1, Z-2 and Z-3, for Pattern 2.

## 5. CONCLUSION

Based on the results of the current study, crew cabins are compact spaces with low heights, where the crew occupies most of the space volume. That is why inlet air parameters, and air distribution systems for such cabins must be handled very carefully when designing the ventilation system.

Additionally, mass flow rate to cabins occupied with large crew, need to keep constant in case of reducing heat load to maintain the required indoor air quality (IAQ) (ADPI =0.94 & APDIlim=0.9).

## REFERENCES

- International Labor Organization (ILO), (2020) ‘Maritime Labour Convention (MLC), 2006, as amended 2020’.
- Chen J., Wang W., Qu M., and Yin W., (2015) ‘Study on Hot Air Distribution of Ship Cabin Air Conditioning’, *Procedia Eng.*, vol. 121, pp. 1420–1427, 2015.
- Nawaz H. and Yuan Y. S., (2013) ‘Thermal comfort analysis of a ship air-conditioning system using solidworks flow simulation’, *Adv. Mater. Res.*, vol. 773, pp. 883–888, 2013.
- Makhoul A., Ghali K., and Ghaddar N., (2013) ‘Desk fans for the control of the convection flow around occupants using ceiling mounted personalized ventilation’, *Build. Environ.*, vol. 59, no. 2013, pp. 336–348, 2013.
- Makhoul A., Ghali K., and Ghaddar N., (2013) ‘Thermal comfort and energy performance of a low- mixing ceiling-mounted personalized ventilator system’, *Build. Environ.*, vol. 60, no. 2013, pp. 126–136, 2013.

- Rees S. J. and Haves P., (2013) ‘An experimental study of air flow and temperature distribution in a room with displacement ventilation and a chilled ceiling’, *Build. Environ.*, vol. 59, pp. 358–368, 2013.
- American Bureau of Shipping (ABS), (2016) ‘Guide For Crew Habitability On Ships’, ABS publication February, pp. 1–95, 2016.
- Det Norske Veritas - Germanischer Lloyd (DNV-GL), (2017) ‘Rules for Classification on Ships Edition October 2015 Amended July 2017 Part 6 Additional class notations Chapter 8 Living and working conditions’, no. October 2015, 2017.
- Ali A. A., (2012) ‘CFD Investigation of Indoor Air Distribution in Marine Applications’, *European Journal of Scientific Research* vol. 88, no. 2, pp. 196–208, 2012.
- Paliaga G. et al., (2010) ‘Thermal environmental conditions for human occupancy’, *ASHRAE Stand.*, vol. 8400, no. STANDARD 55, pp. 1–44, 2010.
- Wang S. K., (1994) ‘Handbook of air conditioning and refrigeration’, vol. 32, no. 02. 1994.
- Alan kabanshi, (2017) ‘Experimental study of an intermittent ventilation system in high Occupancy spaces doctoral thesis university of Gavale.

# The impact of developing navigational aids on improving navigation safety and evaluated the effectiveness of the navigational aids along the Egyptian coast from Alexandria to Damietta

Authors: Capt. Mohamed Shendy hemida ibrahim, Capt. Samy Ismail A. M. Youssef

## المستخلص

خلاصة نظرا للنمو الأخير في الموانئ المصرية والذي أدى إلى استقبال أجيال جديدة من السفن وأهمية قناة السويس كممر عالمي للسفن المتجهة شمالا أو جنوبا ، فمن الأهمية بمكان البدء في تطوير وسائل علمية متقدمة لتطوير المساعدات الملاحية على الساحل المصري لرفع مستوى سلامة الملاحة البحرية في هذه المناطق الحساسة. تبحت هذه الورقة في تقييم السفينة عايدة / ٤ للمساعدات الملاحية على ساحل البحر الأبيض المتوسط خلال رحلة من منارة العجمي في الغرب إلى منارة دمياط في الشرق من عام ٢٠١٦ إلى عام ٢٠٢٠. استخدام نظام التعرف الآلي الافتراضي (VAIS) ، وكذلك الممرات والوسائل الملاحية الافتراضية مع تنفيذ مسح لآراء بعض الملاحين أثناء المرور في هذه المواقع المتعلقة بهذه الاختبارات في موانئ الإسكندرية وأبو قير ، ودمياط ، كشفت هذه الورقة عن عدد من النتائج المهمة ، من بينها وجود عيوب خطيرة في كفاءة تشغيل المساعدات الملاحية ، بهدف تقديم أكثر التوصيات العملية لتحسين كفاءة هذه المساعدات من خلال استخدام التكنولوجيا الجديدة مثل VAIS.

## Abstract

The recent growth of Egyptian ports, which has resulted in the reception of new generations of ships and the importance of the Suez Canal as a global corridor for ships heading north or south, it is critical to begin developing advanced scientific means to develop navigational aids on the Egyptian coast in order to raise the level of maritime navigation safety in these critical areas. This paper examined evaluation carried out by marine officer on board M/V Aida4 for the navigational aids on the Mediterranean coast during a voyage from Al-Ajami lighthouse in the west to Damietta lighthouse in the east coast of Egypt from 2016 to 2020. This involved the realization of a series of practical experiments involving the use of a Virtual Automatic Identification System (VAIS), as well as virtual navigation lanes and aids. With the implementation of a survey of the opinions of a group of navigators during the passage in these locations related to these tests in the ports of Alexandria, Abu Qir, and Damietta, This paper revealed a number of significant findings, including the existence of serious flaws in the efficiency of navigational aids' operation, with the goal of offering the most practical recommendations for improving the efficiency of this aid through the use of new technology such as VAIS.

## 1. Introduction

The great growth in the sector of maritime transportation in the Arab Republic of Egypt, particularly in the expansion of seaports and the Suez Canal to accommodate contemporary ships, it is critical to assess the safety of maritime navigation in these areas. The purpose of this research paper is to examine and evaluate the effectiveness of navigational aids, as well as to assess navigational hazards along the navigation route from Alexandria to Port Said, through the continuous passage of navigational aids in these areas, which are represented by a total of six lighthouses, in addition to the buoys for the ports of Alexandria, Abu Qir, and Damietta, along the navigation route, by using the ship Aida /4 throughout four years, totaling 44 passes. As a result, the importance of the research paper became apparent in selecting the best modern technologies after conducting their own tests to determine the most effective means of increasing the efficiency of navigational aids' operation, resulting in an increase in maritime navigation safety.

### **The current status of navigational aids for the Egyptian coast in the Mediterranean**

With the current development of the ports of Alexandria, Abu Qir, and Damietta, as well as the development of the Suez Canal, including the deepening of the canal's navigational route, allowing safe passage for ships with deep draughts up to 66 feet, and the increase in the canal's carrying capacity as a result of the duplication of a large portion of the canal, the Suez Canal's capacity has increased significantly. Ships passing through the Suez Canal, particularly huge ships, as a result, it was necessary to begin enhancing the shipping route along the Egyptian Mediterranean coast, as well

as the ports of Alexandria, Abu Qir and Damietta with advanced navigational to keep up with technological advancements in electronic equipment on board ships.

### **1.1 Navigational aids in the port of Alexandria**

By the use of Aida IV, the racon and the light of the Ras El-Tin and Ajami lighthouses and the navigational aids in the navigational passage, as well as the Differential Global Positioning System (DGPS) station in El-Max, were followed up in the port of Alexandria through a periodic follow-up over four years from 2016 to 2020. The racon signal appeared as stated in Table (2), "34" times out of a total of "44" passes of the Ras El-Tin lighthouse over a four-year period. The light appeared "26" times out of a total of "44" occasions, representing a percentage of 59.1 percent, which is an unsatisfactory percentage. It is well observed that the Ajami lighthouse's racon's signals only "15" times out of a total of "44" times pass by at a rate of 34.1 percent, as stated in Table (2), and the appearance of illumination 22 times out of a total of 44 times passes by at a rate of 50 percent, which is a very small percentage in relation to the importance of the lighthouse in terms of approving ships approaching the anchorage area or entering the port of Alexandria or Dekheila, as shown in Table (1), as well as the difficulty of determining the signal of the racon of the Ajami lighthouse when approaching the port of Alexandria through the radar screen of the ship Aida IV except at very limited angles, as shown in Figure (1), which leads to the inability of ship's masters to fix their ships' position by using this lighthouse. This implies that the lighthouse is unable to guide ships in this high-traffic area, and it is noticeable that by ships, when passing by the Al-Ajami lighthouse, the lighthouse is located near a significant number of coastal buildings, which

has an impact on the racon's efficiency and the lighthouse's brightness. By observing El-Max DGPS station's technical condition, it was observed that the station has been malfunctioning since the beginning of 2018, affecting the accuracy of ship's locations in this area, as well as the interference observed on the Global Positioning System (GPS) by the use of the ship Aida IV during its voyages from 2016 to 2020, as well as the navigational warning No. 013 of 2019, issued by the US Department of Maritime Affairs (US. MARAD), on September 24, 2019, which indicated that (GPS) satellite systems are being interfered with in several areas in the eastern Mediterranean, posing a threat to navigational safety and the marine environment in this vital region. (US MARAD, 2019)

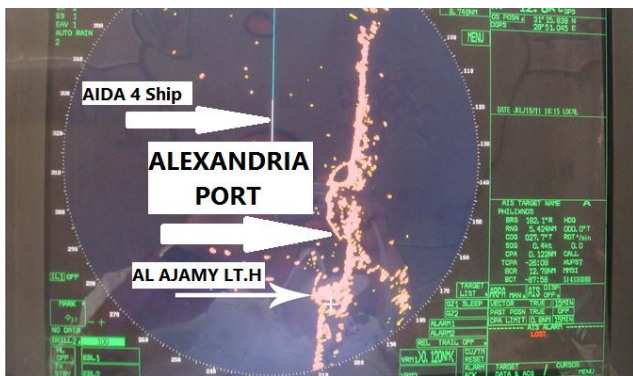

Figure (1): The weak signal of the racon of the Ajami lighthouse on the radar screen.

Source: Photograph from the ship's radar Aida IV while at sea (7/2019).

By monitoring the navigation route of the port of Alexandria, it was noticed the absence of a number of shipping route buoys in the locations designated for them on multiple occasions over the course of four years, from 2016 to 2020, as a result of the impact of bad weather at various times of the year, which affects the safety of navigation for ships while entering or leaving Alexandria's harbor.

## 1.2 Navigational aids in Abu Qir area

The technical condition of the navigational aids and navigational routes for the area of Abu Qir and Idku ports has been monitored continuously from 2016 to 2020. The navigational aids are represented by Nelson Island Lighthouse and Rashid Lighthouse, as a result of ongoing development in Abu Qir port and the establishment of a massive container handling station with a capacity of 2 million containers, it was noticed that the Nelson Island lighthouse's racon signal was observed 6 times out of a total of 44 passes over the course of 4 years, at a rate of only 13.6 percent, as presented in Table (2), as well as the appearance of lighting for 8 times out of a total of 44 passes at rate of only 18.2 percent, which is a very low percentage in relation to the lighthouse's importance, as presented in Table (1). Rashid lighthouse's racon signal appeared 29 times out of a total of 44 passes with 65.9% as presented in table (2).

As shown in Figure (1), the lighting is only 10 times out of a total of 44 passes with 22.7 percent, which is an unacceptable percentage as it affects the safety of navigation in this important shipping and economic area on the Egyptian coast for ships approaching and entering ports or passing through the shipping route (Alexandria-Port Said). Figure (2) depicts Aida IV ship's radar photo while sailing through the Abu Qir area, where there are no electronic navigational aids to guide ships in this densely trafficked area.

As a result of the large number of fishing vessels fishing by trawl nets at night in the shipping route (Alexandria-Port Said), as well as in the shipping routes for entering the ports of Abu Qir and Edkou, with no commitment fishing vessels to the areas designated for fishing outside the shipping route nor its navigational lights, as shown in

Figure (2), for the radar of the ship Aida IV while sailing in the Abu Qir area, which harmed the safety of navigation of passing ships.

As a result of all of the foregoing, an urgent and pressing need has arisen to find practical and expedient solutions to raise the technical level of navigational aids in this important shipping and economic area, including the development of advanced technological means to track fishing vessels present in large numbers while sailing in the Abu Qir area, as this is one of the factors that seriously affect safety of navigation.

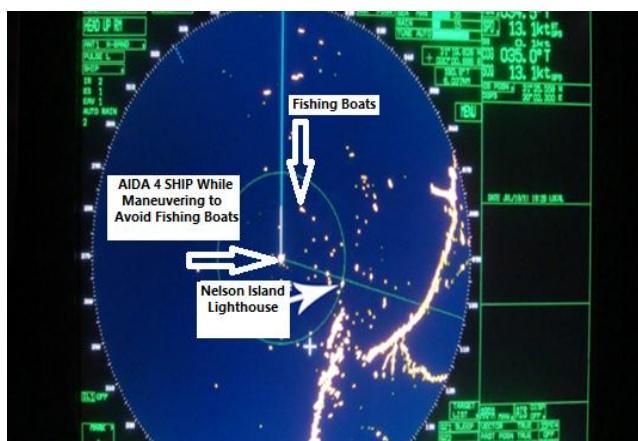

Figure (2): The poor efficiency of the navigational aids operation in Abu Qir Bay.

Source: Photograph from the ship's radar Aida IV during sailing (01/2020).

### 1.3 Navigational aids in the navigation route (Borollos - Damietta)

The shipping route from Burullus to Damietta is considered one of the most important shipping routes on the Egyptian coast. Due to the high density of ships, oil platforms, and fishing vessels in this area, the careful monitoring of the raccoon and lighting of the Burullus and Damietta lighthouses, as shown in table (1) and (2), it was observed that the appearance of the Burullus lighthouse raccoon for 22 times at a rate of 50

percent, as well as its lighting for 25 times at a rate of 56.8 percent, is considered an unacceptable percentage for such an important navigational area. The Damietta lighthouse raccoon, as well, appeared 14 times at a rate of 31.8 percent, and lighting was detected 19 times at a rate of 43.2 percent, which is considered a very low percentage that jeopardizes the safety of ships in this area. In this important area, there are navigational hazards in addition to the large number of fishing vessels fishing in the shipping route from Damietta to El Burullus without complying with the areas designated for fishing outside the shipping route or with the lights of fishing vessels, which were shown on the Electronic Chart Display and Information System after connecting it to the radar of the ship Aida IV during sailing to avoid colliding with large numbers of fishing vessels, and in turn impacted the maritime safety of navigation in this important shipping and economic area.

In light of the foregoing, an urgent and pressing need has emerged to find unconventional and rapid solutions to raise the technical level of navigational aids at the lowest possible cost and in the shortest possible time, with the best possible results, as well as to find advanced technological means to monitor fishing vessels present in large numbers while sailing from Alexandria to Damietta.

To improve navigational aids in accordance with global advancements, practical experiments were carried out with the VAIS to ensure the system's suitability for the nature of the Egyptian coast. This is the first experiment of its kind in the Arab Republic of Egypt's Mediterranean Sea.

Table (1): The status of the illumination of the navigational aids for the Egyptian coast in the Mediterranean Sea during 44 passes

ROSETTA L.T.H		NELSON ISLAND L.T.H		AL AJAMY L.T.H		RAS AT TIN L.T.H	
UNLIT	LIT	UNLIT	LIT	UNLIT	LIT	UNLIT	LIT
34	10	36	8	22	22	18	26
77.3%	22.7%	81.8%	18.2%	50%	50%	40.9%	59.1%
DAMIETTA L.T.H		AL BURULLUS L.T.H					
UNLIT	LIT	UNLIT	LIT				
25	19	19	25				
56.8%	43.2%	43.2%	56.8%				

Source: Reports of the Egyptian Authority for Maritime Safety 2016-2020).

Table (2): The status of a raccoon of the navigational aid for the Egyptian coast in the Mediterranean, while during 44 passes

NELSON ISLAND L.T.H		AL AJAMY L.T.H		RAS AT TIN L.T.H	
Working	Not Working	Working	Not Working	Working	Not Working
6	38	15	29	34	10
13.6%	86.4%	34.1%	65.9%	77.3%	22.7%
DAMIETTA L.T.H		AL BURULLUS L.T.H		ROSETTA L.T.H	
Working	Not Working	Working	Not Working	Working	Not Working
14	30	22	22	29	15
31.8%	68.2%	50%	50%	65.9%	34.1%

Source: Reports of the Egyptian Authority for Maritime Safety 2016-2020).

## 2. Practical experiments carried out in the Mediterranean

After a detailed monitoring was carried out to check the efficiency of the operation of the navigational aids in the port of Alexandria, Abu Qir area, and the navigation route from Burullus to the port of Damietta, it became clear that there is a significant deficiency in the efficiency of the operation of most of the navigational aids due to

several factors, including, but not limited to, the age of racons and searchlights, as well as the direct impact of the buildings located behind the Ajami lighthouse, which reduces the chances of a racon signal appearing on ships' radar.

### 2.1 The practical experiment that was carried out in the port of Alexandria

The virtual AIS (AtoN) were installed at Al-Agamy Lighthouse and the GREAT PASS BEACON in the navigation route at the entrance to the port of Alexandria as part of the practical experiment. In January 2020, this experiment was carried out on the ship Aida IV with the help of the Virtual AIS AtoN. The experiment was conducted in inclement weather in order to acquire results in inclement weather, and meteorological data were taken, which revealed that the wind speed was 19 knots, the wave height was 2.5 to 3 meters, and the atmospheric pressure was 1005 millibar.

The experiment began when the ship Aida IV was moored in the port of Alexandria, and a virtual navigation route was established with six virtual buoys numbered A1 through A6, as well as a virtual position for Beacon GREAT PASS BEACON, as illustrated in Figure (3).

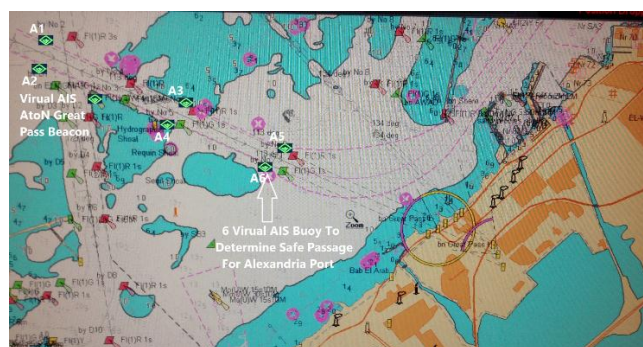

Figure (3): The ship Aida IV during the implementation of the practical experiment in the port of Alexandria.

Source: Photo by Transas ECDIS of Aida IV (1/2020)



The ships entering or departing the port of Alexandria, as well as ships approaching the port anchorage area, were watched for a 12-hour period by the ship Aida IV while it was berthed in Alexandria port to observe how they reacted when using the virtual navigation route by use of RADAR, ECDIS, and AIS. In addition, they used GREAT PASS BEACON to fix their ship's positions.

During the implementation of the practical experiment, a survey was conducted on 17 ships using a VHF device, asking a series of questions as given in Table (3) during entry and exit from the port of Alexandria. The survey's outcome was confirmed after receiving the responses and analyzing them using the percentage computation. The survey found that 16 ships out of a total of 17 ships used the virtual navigation route with ease of identifying the GREAT PASS BEACON through RADAR, AIS, and ECDIS, ensuring that the ships benefit from all of the capabilities of virtual navigational aids, namely (identifying the type of the buoy, its name, the accuracy of its location, bearing and distance from the navigational aid, as well as the reception of weather information, and navigational warnings emphasizing the use of the Maritime Mobile Service Identity (MMSI) number for easy messaging with navigational aids in emergency situations. One ship (5.9%) stated the inability to view the virtual navigational route on the RADAR, however virtual navigational aids were observed through the AIS, and ECDIS.

The ship Aida IV departed from the port of Alexandria after the survey was completed, and the virtual navigation route for the port of Alexandria was used, and the GREAT PASS BEACON was easily identified through the RADAR and ECDIS as shown in Figure (4) with

the ship's positions was fixed while leaving the port of Alexandria and sailing through the shipping route (Alexandria - Port Said).



Figure (4): The ship Aida IV during the implementation of the practical experiment in the port of Alexandria.

Source: Photograph from the ship's radar Aida IV during sailing (1/2020).

## 2.2 The practical experiment that was implemented in the Abu Qir area

It was planned to begin implementing the experiment in the Abu Qir area, using the ship Aida IV as it sailed away from the port of Alexandria. The Virtual AIS AtoN device was programmed with the positions of six buoys for the Abu Qir port navigation route, as well as a virtual position for the Nelson Island lighthouse, as shown in Figure (5) and transmission has started. At a distance of 18 nautical miles, virtual positions in Abu Qir port were observed by Aida IV RADAR, ECDIS, and AIS. During the practical experiment, a survey of 12 ships in the Abu Qir area was conducted by asking a series of questions, as shown in Table (3). Following the responses from the ships' captains, the experiment demonstrated the ease of identifying the virtual navigational aids of the Nelson Island lighthouse, as well as the ease of identifying the safe navigation route for port of Abu Qir near navigational hazards, and the survey result in this experiment was 100% of the number of ships.

A large number of ship captains emphasized the importance of researching the benefits of providing a variety of navigational aids along the coast with the VAIS, particularly in the port areas of Eddko, Abu Qir, Alexandria, and Damietta.

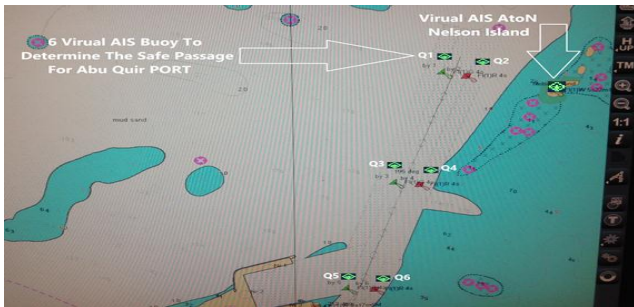

Figure (5): The ship Aida IV during the implementation of the practical experiment at Abu Qir port.

Source: Photo by Transas ECDIS while sailing, Aida IV (1/2020)

### 2.3 The practical experiment that was implemented in the area from Damietta to Al-Burullus

After completing the Suez Canal passage in January 2020, plans were made to begin implementing the experiment in the Damietta port area, using the ship Aida IV while sailing. The Virtual AIS AtoN device has been programmed with 15 virtual locations (5 for waiting area buoys, 6 for the navigational route to enter the port, and 4 for TSS areas), and transmission has begun. The virtual buoys appeared on the Aida IV ship's navigational equipment while the ship was sailing in Traffic Separation System (Port Said-Damietta) at a distance of 17 nautical miles, as shown in figure (6). Because of the nature of the bad weather in January, this month was chosen. During the experiment, the weather was monitored, and the forecast data was (wind speed of 17–21 knots, sea condition of 4–5 Beaufort, atmospheric pressure of 1007 mbar, and wave

height of 2.5–3 meters). The experiment was carried out in this bad weather to assess the system's capabilities in various weather conditions.

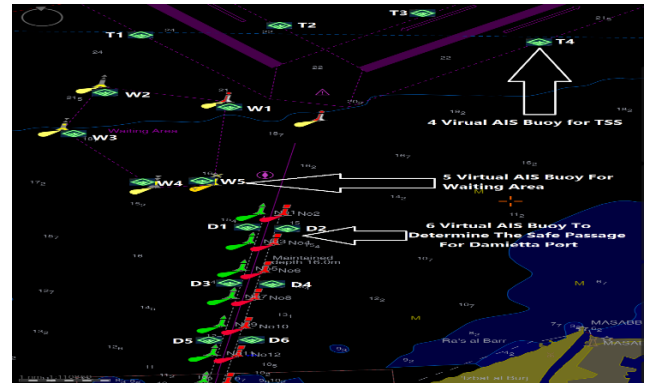

Figure (6): The ship Aida IV during the implementation of the practical experiment in the port of Damietta.

Source: Photo by Transas ECDIS, Aida IV (1/2020)

During the implementation of the practical experiment, a survey was carried out by asking a number of questions as shown in Table (3), by communicating via VHF as well as sending messages via the AIS device using the MMSI numbers of 13 ships navigating the TSS area in front of Damietta. When conducting a survey, it was noticed that the captains and officers of these ships responded quickly due to the importance of advanced navigational aids in guiding ships in this region, which has a high density of ships but is not equipped with modern navigational aids. Following the response from duty officers, the experience revealed that it was easy to identify the virtual navigation aids through (RADAR, ECDIS, and AIS) for 12 ships, at a rate of 92.3 percent, and 1 skipper for a fishing ship, at a rate of 7.7 percent, indicated that they were unable to follow the virtual navigation aids. Because Egyptian fishing vessels do not have an AIS onboard.

After completing the experiment in the Damietta area, preparations were made to begin implementing the experiment in the Burullus area by setting two locations on the Virtual AIS AtoN device (Baltim East GaSFIELD and Baltim South GaSFIELD), and the transmission was started. As illustrated in Figure (7), at a distance of 17 miles, during the practical experiment, a survey was conducted as well, by calling nine ships and asking a series of questions as shown in Table (3). The experiment's survey found that only 2 vessels (22.2 percent) identified and benefited from virtual navigational aids, while 7 fishing vessels (77.8 percent) reported not knowing the system due to the absence of an AIS onboard. As shown in Figure (7), a large number of fishing vessels may be observed, with their non-compliance with international fishing rules that forbid approaching shipping routes, as well as not adhering to fishing vessel lights or shapes, which affect the safety of navigation and the marine environment in this area where a large number of gas platforms are located.

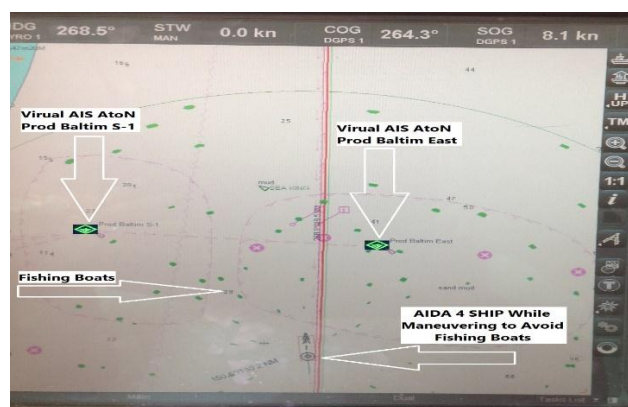

Figure (7): The ship Aida IV during the implementation of the practical experiment in the navigational passage Damietta - Burullus. Source: Photo by Transas ECDIS, Aida IV (1/2020)

Table No. (3): Questionnaire on using AIS AtoN to evaluate work efficiency of navigation aids in Alexandria, Abu Quir and Damietta Ports

1	Are you familiar with the Virtual AIS Aton?
2	Did you see the symbol indicating the virtual AIS Aton in Alexandria Port through ECDIS, RADAR and AIS?
3	Did you see the symbol indicating the virtual AIS Aton in Abu Quir Port Through ECDIS, RADAR and AIS?
4	Did you see the symbol indicating the virtual AIS Aton in Damietta Port and Baltim Gas Fields in Al Burullus through ECDIS, RADAR and AIS?
5	Have you been relying on virtual AIS Aton in Alexandria, Abu Quir and Damietta Ports?

### 3. Results

The research paper revealed a number of significant findings, including:

- There is a severe deficiency in the efficiency of the operation of navigational aids in Alexandria, Abu Qir, and the navigational route from Abu Qir to Damietta, which is represented by lighting and racons, as it was indicated that the average efficiency of the operation of all navigational aids' racons is 45.5 percent, and the operation of all navigational aids' lights is 41.7 percent, and subsequently for all navigational aids is 43.6

percent, posing a serious threat to ship safety and thus having a direct impact on the safety of navigation and the marine environment in these critical areas of the Egyptian coast.

- The lack of electronic navigational aids to assist ships in entering Abu Qir port or Idku port or passing through the Alexandria-Port Said shipping route, resulting in a low level of maritime safety in the Abu Qir area, taking into consideration that this area is regarded as one of the most important navigational and economic areas on Egypt's coast.
- As a series of practical experiments were carried out in Alexandria Port, Abu Qir Port, and the shipping route from Damietta to Burullus using the AIS AtoN, the experiments demonstrated that the system was unaffected by the nature of the Egyptian coast, the prevailing bad weather, or the high density of ships. In addition to the ease of identification and recognition of it by ship captains by using ECDIS, RADAR, and AIS.
- The survey of the practical experiments that were carried out in January 2020 in Alexandria, Abu Qir, Burullus, and Damietta using Virtual AIS AtoN revealed the ease of use by 42 out of a total of 51 ships, equal to 82.4 percent, for virtual aids and routes, as well as the inability of 9 fishing vessels, equal to 17.6 percent, to identify the system due to a lack of AIS on board the Egyptian fishing vessels.

#### 4. Recommendations

- Due to the racon's inefficiency with these lighthouses, Ras El-Tin, Al-Ajami, Nelson Island, Rashid, Burullus, and Damietta

lighthouses need to be equipped with a Virtual AIS AtoN system to supplement the racon.

- The Virtual AIS AtoN is to be utilized in navigation routes for the ports of Alexandria, Dekheila, Abu Qir, Adku, and Damietta.
- The installation of a GREAT PASS BEACON with Virtual AIS Aton near the port of Alexandria's entrance is vital since the beacon is vital for directing ships into both the Alexandria and Dekheila ports.
- The use of the Virtual AIS Aton system during the port's passage, which assists shipmasters in selecting a safe navigation route, especially in foggy conditions.

#### References

- TransNav, (2016), "Correlation of Virtual Aids to Navigation to the Physical Environment" [Correlation%20of%20Virtual%20to%20Navigation%20to%20the%20Physical%20Environment.pdf](#). Cited on 15th January 2019 Available online.
- NATO Shipping Center, (2019), "GPS interference and possible jamming with potentially dangerous consequences is reportedly occurring in the Eastern Mediterranean in vicinity of Cyprus and the entrance to the Suez Canal since the beginning of 2018".
- Nautical Publication 5012, (2019), "Admiralty Guide to ENC Symbols used in ECDIS", London, UK. UKHO.

- Nautical Publication 77, (2019), “Admiralty list of lights and FOG signals” London, UK. UKHO.
- Nossier, (2011), “Benefiting from the automatic dating system to increase the safety of maritime navigation” Master’s thesis submitted to the Arab Academy for Science, Technology and Maritime Transport, Alexandria.
- Rashad R., (2017), “Applications of the Virtual and Enhanced Aids to Navigation in Integrated Ports “The International Maritime Transport & Logistics Conference (MARLOG 6).
- Wright R. G., (2017), “Virtual aids to navigation “Ph.D. Dissertations, World Maritime University.
- Reports of the ship Aida 4 related to traffic on navigational aids (2016-2020), the Egyptian Authority for Maritime Safety, Alexandria: 2020.
- U.S. Maritime Administration (US. MARAD) (2019), Marine notice no.13/2019 “<https://www.maritime.dot.gov>. Cited on 19th may 2019 available online.
- Yang. Q (2017), “Study on the impacts of AIS application on aids to navigation system in Zhanjiang Port “Thesis submitted to the World Maritime University.

# Effect of the Suez Canal on Marine Invasive Species Entry to the Mediterranean and Methods of Mitigation.

DR. Mamdouh Awad Abdelrahman Shahhat

## المستخلص

البحار تلعب دور مهم في تحقيق التنمية الاقتصادية للشعوب وتوفير الغذاء الامن وتقليل الفقر. ولكن للنقص الشديد في التنسيق بين العوامل الخارجية والصحاب المصلحة (المنتفعين من الموارد البحرية) من مختلف القطاعات ادي الي حدوث نزيف للموارد البحرية الطبيعية. تأثير الكائنات الغازية علي الشعوب يفوق تاثير الكوارث الطبيعية من الناحية الاقتصادية. والكائنات البحرية الغازية استوطنت البحر الابيض والقادمة من البحر الاحمر عبر بوابة قناة السويس في الاونة الاخيرة وذلك بسبب نقص كمية المياه العذبة المنصبة من نهر النيل نتيجة لبناء السد العالي في ستينات القرن الماضي وتغير المناخ والتلوث البحري وتنمية وتطوير السواحل وكذلك لتعرض والتهديد بالانقراض للمفترسات البحرية مثل السلاحف البحرية والتي تتغذي علي الكائنات البحرية الغازية مثل قنديل البحر. والورقة تركز علي توضيح المعوقات التي تعوق الاستخدام الامثل للموائل البحرية للبحر الابيض المتوسط. وكذلك دراسة الاسباب التي ادت الي ذلك. ومعالجة ذلك من خلال الاعتماد علي التكنولوجيا الحديثة لمنع وتخفيض من حدة انتشار الكائنات البحرية الغازية وكذلك حماية المفترسات الطبيعية كمانع طبيعي. والاهداف الرئيسية هي تحقيق الفائدة الاقتصادية واستدامة الموارد البحرية.

## Abstract

Oceans have significant importance in achieving countries' economic growth, increasing food security, and lessening poverty. However, a lack of coordination between externalities and stakeholders from various departments has caused adverse impacts on marine resources. Invasive marine species' impacts on countries' Gross Domestic Products (GDP) are higher than a natural disaster. In addition, they invaded the Mediterranean as a result of opening the Suez Canal and building the Aswan High Dams in the 1960s decreasing the amount of poured fresh water in the Mediterranean. Moreover, the number of natural predators such as sea turtles along the Mediterranean shoreline of Egypt has decreased because of marine pollution, climate change, and coastal development.

This paper focuses on identifying the challenges impeding the future harnessing of the Mediterranean services and goods. In addition, identifying reasons that led to. This research paper contains qualitative data to examine the significance of depending on developing technologies and natural deterrents of invasive marine species to attain commercial benefits and sustain marine resources as well.

Keywords: Marine Invasive Species, Great Bitter Lakes, Salinity, Acoustic Deterrents, Suez Canal.

## 1. Introduction:

Since the United Nations Conference on Sustainable Development in 2012, The Blue Economy notion has gained popularity. The blue economy has the same driving targets emanated from the 'Green economy' notions where oceans have significant importance in attaining countries' economic development, the social, and environmental targets (Sarjoon, 2021).

The challenges impeding exploitation of the marine resources are divided into two parts, firstly naturally exist because of the wrong notion where seas deemed as everlasting resources for attaining countries' economic goals (María Martínez-Vázquez et al., 2021), and absence of enough states' commitments to the requirements of the UNCLOS treaty (Shiiba et al., 2022).

The second challenge because of human activities, for example, coastal development, global warming impacts, and invasive species that collapse biodiversity and coastal habitats loss (Prakash & Verma, 2022).

The number of invasive marine species in the Mediterranean is about one thousand (Uysal, 2019). In addition, In the last three decades the total cost of the marine invasive species in the Mediterranean was about \$27 billion with annual cost about \$1 billion (Kourantidou et al., 2021).

Challenges impeding the future harnessing of Mediterranean services and goods are divided into two parts. The first challenge is, in retrospect, the reason of constructing the Suez Canal in 1859 was to connect between the Red Sea with the Mediterranean. Moreover, The Suez Canal opened in 1869. The positive attributes of such a connection has facilitated the speed of transportation of goods and the low cost of transportation between countries, decreased the

transit time, and GHGs emissions (Castellanos-Galindo et al., 2020)

What is axiomatic today is that the Suez Canal is considered a link that connects 3 continents namely Asia, Africa, and Europe. Moreover, the trade volume transported by sea represents almost 80 percent of the total world trade (Lee & Wong, 2021). Furthermore, the total number of ships crossed the Suez Canal in 2021 was 20,694 and approximately 1.27 billion tons (Suez Canal Authority, 2021), 12 percent of total seaborne trade (Baker et al., 2021; Martin, 2021). Undoubtedly, Ever Given crises in the Suez in March 2021, economic specialists have determined financial losses from the consequential blocking at \$9.6 billion per day, increasing across-the-board concerns of destructive impacts on the international supply chain (Ghosh, 2021). Furthermore, the Suez Canal is a main pillar of the Egyptian economy whereby the revenue of the Suez Canal was about \$5.3 billion in 2019 (Romer, 2022)

Meanwhile, Great Bitter Lakes (GBL) is situated in the middle of the Suez Canal its water density was considered a natural barrier to prevent invasive species to invade the Mediterranean because the (GBL) water density was higher than both the Red Sea and the Mediterranean but bypassing days as a result of runoff in the (GBL) the water density have diluted and then their salinity equalized with the Red Sea (El-Serehy et al., 2018) while the salinity of the Mediterranean increased after the rate of freshwater pumping to it decreased with the establishment of the Aswan high dam in the 1960s (Soliman et al., 2021). Furthermore, increasing the (GBL) water depths to accommodate the giant ships with big drafts has decreased the water salinity in the lakes

(Biton, 2020). Thus, decreasing the water salinity in the (GBL) have facilitated crossing marine invasive species the Suez Canal.

The second reason that enabled marine invasive species to invade the Mediterranean is the number of natural predators has reduced such as sea turtles and which feed on some of the invasive marine species for example jellyfish. Moreover, sea turtles according to IUCN Red List on the Mediterranean coast of Egypt are considered a threatened marine species and critically endangered. In contrast, Invasive Alien Species (IAS) Such as lionfish and which invaded the Mediterranean in 2012, and jellyfish bloom causing adverse impacts on public health and tourism activities (Castellanos-Galindo et al., 2020). Furthermore, jellyfish feed on indigenous species such as fish larvae and shrimps (Otero et al., 2013). Thus, they depleted the food web and cause cumulative impacts on biodiversity in the Mediterranean (Corrales et al., 2018).

Therefore, for a more sustainable ocean economy, cooperation between stakeholders with the government is required. Thus, blending management with science would control and prevent the spread of marine invasive in the Suez Canal that is through studying the movements of the marine invasive species by detecting them by using environmental DNA (Yip et al., 2021) or Underwater Autonomous Vehicle (UAV), and acoustic sonar (Martínez-González et al., 2021). Therefore, its spread can be reduced by depending on emerging technology methods, for example, electrical, acoustic, and hydrological deterrence (Castellanos-Galindo et al., 2020). In addition, this paper aims to address, and analysis of the reasons that led to the spread out of alien species from the Red Sea to the Mediterranean via the Suez Canal. Furthermore, it examines the

relevant deterrents and ways to limit and control their spread out. To, rehabilitate the East Mediterranean ecosystem.

## **2. Marine Invasive Species in the Mediterranean:**

The main reasons for marine species' invasion of the Mediterranean are Suez Canal, vessels (ballast water and sediments, hull fouling), global warming, and fish farms. However, some marine invasive species attain economic profits in the Mediterranean fish market (Kleitou et al., 2022).

The sea surface temperature of the Mediterranean Sea in the last four decades has shown a warming trend (0.13 °C/y) above those specified by the Intergovernmental Panel on Climate Change (IPCC) (0.035 °C/y, 2016–2035). Moreover, the marine protected areas (MPAs) in the Mediterranean have been invaded by non-indigenous marine species. Therefore, they have caused a significant environmental, social, and economic impacts (Galil et al., 2017).

### **2.1 Untreated Ballast Water and Ships Fouling**

Changing ships' ballast water either at sea or in ports transfers about ten thousand alien species on daily basis from one place to another. Moreover, the amount of ballast water transferred via ship from one country to another is about 10 billion tons annually (Saglam & Duzgunes, 2018). The entry of alien marine species from the Red Sea to the Mediterranean through the Suez Canal may occur either by a deliberated action from ships, for instance, changing untreated ballast water or accidentally adhesion alien species on the giant vessel's fouling underwater hull (Bereza et al., 2020).

The last extension of the Suez Canal in 2015 has helped in increasing the number of tons of



seaborne cargo transiting the Suez Canal because it targeted an economy of scale ships. Thus, this led to a significant increase in the number of tons transported compared to the number of ships transiting the canal (Bereza et al., 2020). However, the Suez Canal has contributed to a raise in the number of alien marine species such as lionfish and jellyfish that are transported through ships either by untreated ships' ballast water (Wang et al., 2022) or by ship's hull fouling that accumulated on the submerged hull. In general, the alien marine species have invaded the Mediterranean and caused adverse environmental, socioeconomic impacts (Atvur & Oğuz, 2019).

## 2.2. Bitter and Timsah Lakes

Historical Great Bitter Lakes (GBL) is named because of its high evaporation rates and low rainfall. In addition, the degree of salinity of the Mediterranean and the Red Sea was less than of the lakes. So, the (GBL) was a natural barrier, which prevents transferring marine species from the Red Sea to the Mediterranean. The (GBL) represents almost a quarter of the Suez Canal in terms of length and about 85 percent in terms of the canal's water volume (El-Serehy et al., 2018).

On the other hand, over time, the natural barrier has disappeared because the salinity of the lakes has decreased and neutralized with the Red Sea salinity (Hossain, 2018). In addition to, the new bypass for the Suez Canal (See Figure 1) pass away from the Timsah lake has helped the invasive species transit without passing through the Timsah lake which was natural barrier preventing the nonindigenous species to cross the Suez canal toward the Mediterranean (Bereza et al., 2020).



Figure 1: GBL before & after last expansion in August 2015

Source: (Bereza et al., 2020).

The water density in the GBL has been diluted for two reasons. The first reason is due to increasing the water depth in the Suez Canal expansions to enable the lakes to accommodate giant vessels with big drafts (WÜST, 1935) (El-Serehy et al., 2018) (Biton, 2020) (See Line Graph 1). The second is the increase in drainage freshwater, whether agricultural or industrial (Abd-El-aziz, 2021). Therefore, human activities and unsustainable use of marine resources have caused adverse environmental impacts.

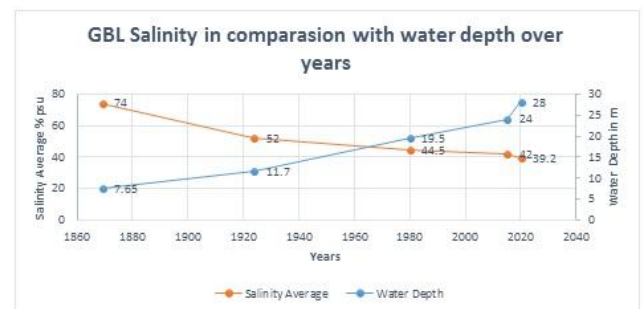

Line Graph (1): GBL salinity changing in comparison with water depth over years

Sources: (WÜST, 1935); (El-Serehy et al., 2018); (Biton, 2020).

## 2.3 Aquaculture

In recent years, Egypt's production of fish farms has increased to fill the gap between the supply and demand of fish and secure food for millions of people. In addition, Egypt comes in first place in Africa in aquaculture production. Furthermore,

Egypt's yearly production of fish is almost 2 million tons, about 1.6 from aquaculture and 0.4 million tons from natural resources, so the aquaculture produces 80 percent of the total fish production in Egypt, and about 24 kg per capita (FAO, 2021).

On the other hand, fish farms are a source of marine invasive species (Saber et al., 2022). Moreover, marine invasive species introduced accidentally as a result of, for instance, they attached with the desired introduced ones in fish farms (Mannino et al., 2017). In addition, the marine invasive species introduced due to the absence of adequate monitoring and legislation in some fish farms locations (Zahran et al., 2021).

## 2.4 Climate Change

In the last three decades from 1991 to 2020, the sea surface temperature (SST) of the Mediterranean coast of Egypt has increased approximately 1.5° C while in a century the average world temperature has increased by almost 0.75°C. Furthermore, in the Mediterranean approximately 52 types of invasive species, 47 of which come from the Red Sea via the Suez Canal and five from the Atlantic ocean (Gentilucci et al., 2021). Therefore, the raised in seawater temperature has helped in increasing the number of invasive species numbers from the Red Sea to the Mediterranean via the Suez Canal (Tang & Hadibarata, 2022).

Climate change and alien invasive species are the biggest factors causing adverse impacts on the Mediterranean marine resources and biodiversity. In addition, the average world temperature has raised about 0.74° C in the last century (Gentilucci et al., 2021). Moreover, recently marine invasive species have invaded the Mediterranean and they have decreased fish production and biodiversity. Thus, invasive

species have caused environmental and social impacts (Bonanno & Orlando-Bonaca, 2019). Furthermore, global warming impacts as the warming of the Mediterranean make conditions more favourable for the movement of species from the Red Sea toward the Mediterranean through the Suez Canal (Gentilucci et al., 2021).

## 2.5 Scarcity of Natural Predators

Sea turtles are considered a deadly marine trap for some kinds of non-indigenous species. Because jellyfish is a favourable target for sea turtles to feed on ( See Figure 2) (P. Casale et al., 2021).

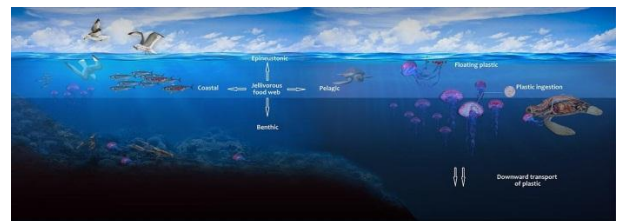

Figure 2. Green sea turtle feeds on jellyfish and floating plastic.

Source : (Macali & Bergami, 2020)

There are three types of sea turtles in the Mediterranean, namely (Green, leatherback, and loggerhead). Furthermore, the Egyptian Mediterranean shoreline is the preferred location for nesting and feeding sea turtles (green and loggerhead) (Casale et al., 2021) especially in Bardwell lake (Attum & Rabia, 2021).

However, there are many threats affect the marine turtle population in the Mediterranean either accidentally, such as boat strikes, illegal fishing (dynamite fishing), and bycatch or deliberate, for instance, marine pollution (plastic, oil, and sewage), coastal development, and climate change (P. Casale et al., 2021).

Egyptian fishers target sea turtles despite their consumption, and catching are prohibited and illegal nationally and internationally because their

valuable meat (National Marine Fisheries Service & U.S. Fish and Wildlife Service, 2021). Furthermore, According to the International Union for Conservation of Nature (IUCN) report, all three sea turtles are on the Red List of threatened marine species. Where green turtles are categorized as endangered while both leatherback and loggerhead are categorized as vulnerable (Abdelwarith & Jribi, 2020). In addition, the highest mortality rates of marine turtles in the Mediterranean because of fishing gears (Casale et al., 2018).

In terms of management and legislation, Egypt is obligated by international conventions regarding protecting marine species and maintaining biodiversity, such as the Barcelona convention 1976 and its amendments 2000 regarding Protection of the Marine Environment and the Coastal Region of the Mediterranean. Moreover, Egypt ratified the Convention on Biological Diversity (CBD) and the Convention on Wetlands (RAMSAR). Furthermore, In 2017 Egypt developed National Action Plan by a team of subject matter experts and supported by the collaboration between the Egyptian Environmental Affairs Agency (EEAA) with UNEP/MAP Regional Activity Centre for Specially Protected Areas (RAC/SPA). However, people's awareness and change in their behaviours, and capacity building are needed actions by decision-makers to protect endangered and vulnerable sea turtles (Naguib et al., 2020).

### **3. Mitigation of marine invasive species impacts in the Mediterranean**

Egypt seeks to limit and mitigate the spread out of IAS along the Mediterranean coast of Egypt and at ports in order to protect the marine environment. Moreover, Egypt is a member state and committed by the Barcelona Convention

measures, which was adopted in 1976 and entered into force in 1978. Furthermore, under this treaty, member states, either separately or jointly, undertake to take all suitable actions to save and maintain biological diversity in the Mediterranean (Atvur & Oğuz, 2019).

In addition, relying on emerging technologies in the early detection stage could limit and mitigate invasive marine species' spread out. Because if they invaded a novel area, it is no longer possible to limit their spread out (Deák et al., 2021). Therefore, using all trials to eradicate marine invasive species and if not possible, all efforts will be on preventing their introductions (Cupp et al., 2018). In addition, using modern technologies as a non-physical barrier in monitoring and controlling alien invasive species will be a more appropriate method in terms of time and cost (Martinez et al., 2020).

#### **3.1 Desalination plants**

Egypt is turning to desalination plants as a strategic alternative to confront the expected decrease of freshwater from 53 billion m<sup>3</sup> (BCM) to approximately 50 billion m<sup>3</sup> (BCM) in the year 2025 (Tran et al., 2016) (See Line Graph 2). Moreover, the population increase, and the economic growth will increase the need for water. Therefore, relying on desalinated water will increase to achieve the united nations agenda regarding sustainable development goals in 2015 to eradicate poverty by 2030 (Kotb et al., 2021).

Increasing the salinity of the Bitter Lakes through relying on the disposed of brine water of desalination plants located near the Bitter Lakes (Castellanos-Galindo et al., 2020) such as Ismailia drinking water desalination plant in Timsah Lake (El-sharkawy et al., 2021). Yet, disposal of brine water from desalination plants changing both water salinity and dissolved

oxygen that has negative effects on the environment (El-Hady Kashyout et al., 2021). Meanwhile, the brine water disposed of by desalination plants in the (GBL) increases the water salinity. Therefore, increasing the salinity of the (GBL) will work as a non-physical barrier preventing invasive species to invade the Mediterranean (Castellanos-Galindo et al., 2020). However, this process should be under control and monitored to avoid undesired consequences on the environment.

### 3.2 Analysis Samples of Ballast Water tanks Environmental DNA

The first step is to detect targeted invasive species by analysing samples of ships' ballast water tanks by using environmental DNA (See Figure 3) (Rey et al., 2019) and tracking them by using SONAR where early detection will ease the process of surveillance. After that, a surveillance process via either on small scale, for example, using images or videos, or on a large scale (remote sensing) by using environmental drones or satellites. Thus eradicating and preventing targeted alien species of spread out, will be a quite easy process (Juanes, 2018).



Figure 3: Taking a sample of a ship's ballast water tank.

Source: (Rey et al., 2019)

The use of environmental DNA is distinguished from traditional methods in the surveillance process by the fact that it is low cost and high-

accuracy in discriminating between targeted species as well as in the process of a strong scientific evidence (Morissette et al., 2021). Today, Managing invasive species by using artificial intelligence (AI) image recognition either image or video can test the image of selected invasive species and obtain computerized results of targeted species within seconds (Morissette et al., 2021).

The International Maritime Organization (IMO) via the 2017 Ballast Water Management Convention has enforced guidelines and commitments to decrease the spread out of marine invasive species via ship ballast water, and hull biofouling (Wang et al., 2022). Moreover, Egypt has ratified the Ballast Water Management Convention since 2004.

### 3.3 Electric Barrier

Marine species barriers are divided into two types, physical and non-physical deterrents. In addition, physical barriers such as dams and weirs that prevent passing both of native and alien species (Zielinski et al., 2019). Moreover, electric deterrent is non-physical system and more influential and more damaging than other fish deterrent methods (Yalçinkaya et al., 2017). Furthermore, the electric barrier kills both alien and native species. Moreover, using the electric deterrent will be good in water that has low recreational activities and it is lower than physical barriers in maintenance costs (Johnson et al., 2021). However, electric and physical (weirs and locks) barriers are not always fully effective to prevent invasive species spread out (Treanor et al., 2017) because small fish may not be affected by the electric barrier (Suski, 2020).

The method of electric barriers is done by installing sensors in the barrier that differentiate between native and non-native fish by allowing

native fish to pass through spawning groups and prevent and eliminate the non-native fish from the passage. Moreover, There is not a single registered case of injury or death of people due to the electrical barrier (Zielinski et al., 2019).

### **3.4 Underwater Acoustic Barrier**

The acoustic deterrent is a nonphysical barrier contained on speakers and sound bubbles curtains decreasing fish mortality because sound plays a key role in fish behavior a method used to guide native species to desired locations away from human activities by affecting the sensory system of fish by issuing attraction stimuli and at the same time decrease spread out of alien species by disgusting stimuli. In addition, Sound has innate advantages in comparison with light and odor because the underwater sound is weakened at a slow pace, long-range, ease of orientation, and directing not obstructed by low light or water turbidity. However, some alien species navigate away from acoustic stimuli. In addition, sound bubbles curtains are affected by the current and the movement of ships. Moreover, Acoustic deterrents are not fully controlling for some species and need quite relevant conditions. Furthermore, to avoid environmental and economic losses technology monitoring is required (Putland & Mensinger, 2019).

### **3.5 Pumping Dissolved CO<sub>2</sub> or Deploying Biocides at Sea**

Deploying dissolved (CO<sub>2</sub>) solution into water is the best emerging technology method to keep invasive alien species away from desired locations (Treanor et al., 2017). Moreover, eradicating invasive alien species is an almost impossible option while prohibiting their entry to a novel area is a better possible managing alternative. Furthermore, some fish avoid confined water areas abundant and concentrated

by CO<sub>2</sub> because CO<sub>2</sub> change their behaviour and performance. Therefore, using a threshold level of CO<sub>2</sub> will be relevant in confined areas such as ship locks and yards and a specific season of the year (summer). In addition, fish avoid areas abundant in CO<sub>2</sub> (Suski, 2020). Furthermore, it is a non-physical deterrent that cripples or fends fish and does not impede navigation in a waterway. However, it does not use in streaming water because it failed to meet CO<sub>2</sub> concentrations requirements (Cupp et al., 2021). Moreover, according to some marine invasive species, the threshold level of CO<sub>2</sub> did not influence their avoidance in case they were deprived of food for a while such as Largemouth bass, or because of their personality such as Bluegill. Moreover, a combination between CO<sub>2</sub> and another a non-physical barrier such as an acoustic deterrent could be a fully effective deterrent and at the same time put undesired environmental consequences on native fish into consideration (Suski, 2020).

Poisoning is suitable to eradicate invasive species on land such as red fox but deploying the highly propagated biocides at sea is quite harmful to the marine environment, food web, non-targeted species, and people's health. However, according to experts, deploying biocides in areas completely occupied by marine invasive species, and the presence of native marine species is quite rare is preferable to decrease environmental hazards (Giakoumi et al., 2019).

### **3.6 Do nothing approach**

Early detection of alien species facilitates the process of combating them. But some invasive species for example *C. taxifolia*, when they invade the Mediterranean, at first bloomed and at the end collapsed, so business-as-usual or no intervention techniques and the "do nothing"

decision approaching maybe tackle this issue (Giakoumi et al., 2019).

#### 4. Conclusion:

This paper aims to restoring natural barriers such as re-salting the GBL again, and marine turtle's rehabilitation along the Mediterranean coast of Egypt prevent the marine invasive species to invade the Mediterranean.

The combination between emerging technologies deterrents such as a combination between deploying the CO<sub>2</sub> with electric or acoustic barrier limit the spread out of marine invasive species in desired locations. In addition, applying the "Do Nothing" approach and waiting until the marine invasive species diminished without people intervention is the easiest and cheapest method but careful monitoring is required.

Decision making should take corrective actions to avoid undesired environmental consequences. Thus, by blending management with science would control and prevent the spread of marine invasive species via the Suez Canal. However, a discrepancy between scientists' and stakeholders' preferences for example the researcher prefers to publicize environmental examinations, and stakeholders lean to find governance resolutions.

In this regard, the government trade-offs between establishing projects to attain economic goals or mitigating environmental issues such as marine invasive species spread out.

#### 5. Recommendations:

- 1) Cooperation between stakeholders (fishers, education institutes, shipping lines) and the government is required to decrease marine invasive species spread out.
- 2) Improving education and capacity building in dealing with marine invasive species disaster and their impacts on Mediterranean biodiversity.

3) Do nothing approach but careful monitoring by emerging technologies is required to avoid undesired consequences.

4) Monitoring Marine Protected Areas for marine healthy areas restoration.

5) Eradicating marine invasive species in novel Areas the early detection and a quick response are required.

6) Rehabilitation of endangered marine species such as marine turtles on the Mediterranean coast of Egypt.

Conflict of interest: there is no a conflict of interest. The conflict of interest "Not Applicable"

#### References:

- Kourantidou, M., Cuthbert, R. N., Haubrock, P. J., Novoa, A., Taylor, N. G., Leroy, B., Capinha, C., & Renault, D. (2021). Economic costs of invasive alien species in the Mediterranean basin. 458, 427–458. <https://doi.org/10.3897/neobiota.67.58926>
- Lee, J. M., & Wong, E. Y. (2021). Suez Canal blockage: an analysis of legal impact, risks and liabilities to the global supply chain. MATEC Web of Conferences, 339, 01019. <https://doi.org/10.1051/mateconf/202133901019>
- Macali, A., & Bergami, E. (2020). Jellyfish as innovative bioindicator for plastic pollution. Ecological Indicators, 115, 106375. <https://doi.org/10.1016/J.ECOLIND.2020.106375>
- Mannino, A. M., Balistreri, P., & Deidun, A. (2017). The Marine Biodiversity of the Mediterranean Sea in a Changing Climate: The Impact of Biological Invasions. Mediterranean Identities - Environment, Society, Culture. <https://doi.org/10.5772/INTECHOPEN.69214>
- María Martínez-Vázquez, R., Milán-García, J., De, J., & Valenciano, P. (2021). Challenges of the Blue Economy: evidence and research trends. <https://doi.org/10.1186/s12302-021-00502-1>

- Casale, P., Hochscheid, S., Kaska, Y., & Panagopoulou, A. (2021). Sea Turtles in the Mediterranean Region: MTSG Annual Regional Report 2020. Report of the IUCN-SSC Marine Turtle Specialist Group, 2020, 331.
- Casale, Paolo, Broderick, A. C., Camiñas, J. A., Cardona, L., Carreras, C., Demetropoulos, A., Fuller, W. J., Godley, B. J., Hochscheid, S., Kaska, Y., Lazar, B., Margaritoulis, D., Panagopoulou, A., Rees, A. F., Tomás, J., & Türkozan, O. (2018). Mediterranean sea turtles : current knowledge and priorities for conservation and research. *Endangered Species Research*, 36, 229–267.
- Castellanos-Galindo, G. A., Robertson, D. R., & Torchin, M. E. (2020). A new wave of marine fish invasions through the Panama and Suez canals. *Nature Ecology and Evolution*, 4(11), 1444–1446. <https://doi.org/10.1038/S41559-020-01301-2>
- Corrales, X., Coll, M., Ofir, E., Heymans, J. J., Steenbeek, J., Goren, M., Edelist, D., & Gal, & G. (2018). Future scenarios of marine resources and ecosystem conditions in the Eastern Mediterranean under the impacts of fishing, alien species and sea warming OPEN. *Scientific REpoRtS* |, 8, 14284. <https://doi.org/10.1038/s41598-018-32666-x>
- Cupp, A. R., Lopez, A. K., Smerud, J. R., Tix, J. A., Rivera, J. M., Swyers, N. M., Brey, M. K., Woodley, C. M., Smith, D. L., & Gaikowski, M. P. (2021). Telemetry evaluation of carbon dioxide as a behavioral deterrent for invasive carps. *Journal of Great Lakes Research*, 47(1), 59–68. <https://doi.org/10.1016/J.JGLR.2020.10.004>
- Cupp, A. R., Smerud, J. R., Tix, J. A., Schleis, S. M., Fredricks, K. T., Erickson, R. A., Amberg, J. J., Morrow, W. S., Koebel, C., Murphy, E. A., Vishy, C., & Douglas Blodgett, K. (2018). Field evaluation of carbon dioxide as a fish deterrent at a water management structure along the Illinois river. *Management of Biological Invasions*, 9(3), 299–308. <https://doi.org/10.3391/mbi.2018.9.3.12>
- Hossain, K. A. (2018). Suez Canal : The Modern Maritime Wonder. 1–10.
- Martínez-González, Á. T., Ramírez-Rivera, V. M., Caballero-Vázquez, J. A., & Jáuregui, D. A. G. (2021). Deep learning algorithm as a strategy for detection an invasive species in uncontrolled environment. *Reviews in Fish Biology and Fisheries*, 31(4), 909–922. <https://doi.org/10.1007/s11160-021-09667-7>
- Martinez, B., Reaser, J. K., Dehgan, A., Zamft, B., Baisch, D., McCormick, C., Giordano, A. J., Aicher, R., & Selbe, S. (2020). Technology innovation: advancing capacities for the early detection of and rapid response to invasive species. *Biological Invasions*, 22(1), 75–100. <https://doi.org/10.1007/s10530-019-02146-y>
- Saber, A. A., Borrini, A., Saber, H., El-sheekh, M., Gontcharov, A. A., & Cantonati, M. (2022). A marine invasive benthic diatom species [ *Licmophora normaniana* ( Greville ) Wahrer , 1985 ] in an inland oasis mineral spring in Egypt Rapid Communication A marine invasive benthic diatom species [ *Licmophora normaniana* ( Greville ) Wahrer , 1985 ] in a. March. <https://doi.org/10.3391/bir.2022.11.1.02>
- Saglam, H., & Duzgunes, E. (2018). Effect of ballast water on marine ecosystem. In *Green Energy and Technology* (pp. 373–382). Springer Verlag. [https://doi.org/10.1007/978-3-319-62575-1\\_26](https://doi.org/10.1007/978-3-319-62575-1_26)
- Sarjoon, A. (2021). Conceptual Nexuses between Sustainable Development and Blue-Green Economy: An Analysis of the Importance of Adopting Blue-Green Economic Principles in Achieving Sustainable Development Goals. *Journal of Economics and Sustainable Development*, July. <https://doi.org/10.7176/jesd/12-6-10>
- Shiiba, N., Wu, H. H., Huang, M. C., & Tanaka, H. (2022). How blue financing can sustain ocean conservation and development: A proposed conceptual framework for blue financing mechanism. *Marine Policy*, 139(June 2020), 104575. <https://doi.org/10.1016/j.marpol.2021.104575>

- Giakoumi, S., Katsanevakis, S., Albano, P. G., Azzurro, E., Cardoso, A. C., Cebrian, E., Deidun, A., Edelist, D., Francour, P., Jimenez, C., Mačić, V., Occhipinti-Ambrogi, A., Rilov, G., & Sghaier, Y. R. (2019). Management priorities for marine invasive species. *Science of the Total Environment*, 688, 976–982. <https://doi.org/10.1016/J.SCITOTENV.2019.06.282>
- Johnson, N. S., Snow, B., Bruning, T., & Jubar, A. (2021). A seasonal electric barrier blocks invasive adult sea lamprey (*Petromyzon marinus*) and reduces production of larvae. *Journal of Great Lakes Research*, 47, S310–S319. <https://doi.org/10.1016/J.JGLR.2021.09.008>
- Juanes, F. (2018). Visual and acoustic sensors for early detection of biological invasions: Current uses and future potential. *Journal for Nature Conservation*, 42, 7–11. <https://doi.org/10.1016/J.JNC.2018.01.003>
- Kleitou, P., Moutopoulos, D. K., Giovos, I., Kletou, D., Savva, I., Cai, L. L., Hall- Spencer, J. M., Charitou, A., Elia, M., Katselis, G., & Rees, S. (2022). Conflicting interests and growing importance of non- indigenous species in commercial and recreational fisheries of the Mediterranean Sea. <https://doi.org/10.1111/fme.12531>
- Kotb, K. M., Elkadeem, M. R., Khalil, A., Imam, S. M., Hamada, M. A., Sharshir, S. W., & Dán, A. (2021). A fuzzy decision-making model for optimal design of solar, wind, diesel-based RO desalination integrating flow-battery and pumped-hydro storage: Case study in Baltim, Egypt. *Energy Conversion and Management*, 235, 113962. <https://doi.org/10.1016/J.ENCONMAN.2021.113962>
- Naguib, N. M., Abdelwarith, M. S., & Jribi, I. (2020). Progress of work for monitoring marine turtles along the Egyptian Mediterranean coast. *Natura Croatica*, 29, 45–49. <https://doi.org/10.20302/NC.2020.29.23>
- Soliman, T., Dibattista, J. D., Fahim, R. M., & Reimer, J. D. (2021). Preliminary genetic assessment of three goatfish species in the Mediterranean Sea. <https://doi.org/10.1101/2021.05.23.445364>
- Suski, C. D. (2020). Development of Carbon Dioxide Barriers to Deter Invasive Fishes : Insights and Lessons Learned from Bigheaded Carp.
- Tang, K. H. D., & Hadibarata, T. (2022). Seagrass Meadows under the Changing Climate: A Review of the Impacts of Climate Stressors. *Research in Ecology*, 4(1). <https://doi.org/10.30564/re.v4i1.4363>
- Yalçinkaya, T., Çakır, A., Bolat, Y., Uysal, R., & Aslantas, A. (2017). Electric fish barrier for protecting small carps in Eğirdir lake. *Tehnicki Vjesnik - Technical Gazette*, 24(6), 1641–1646. <https://doi.org/10.17559/tv-20150917105429>
- Yip, Z. T., Lim, C. S., Tay, Y. C., Tan, Y. H. J., Beng, S., Tun, K., Teo, S. L. M., & Huang, D. (2021). Environmental DNA detection of the invasive mussel *Mytella strigata* as a surveillance tool. *Management of Biological Invasions*, 12(3), 578–598. <https://doi.org/10.3391/MBI.2021.12.3.05>
- Zahran, E., Elbahnaswy, S., Mamdouh, A.-Z., & El- Matbouli, M. (2021). Xenosteroids in aquaculture with special consideration to Lake Manzala (Northern delta lake, Egypt): Types, sources and mechanism of action. <https://doi.org/10.1111/are.15504>
- Morisette, J., Burgiel, S., Brantley, K., & Daniel, W. M. (2021). DigitalCommons @ University of Nebraska - Lincoln Strategic considerations for invasive species managers in the utilization of environmental DNA ( eDNA ): Steps for incorporating this powerful surveillance tool.
- Otero, M. del M., Cebrian, E., Francour, P., Galil, B. S., & Savini, D. (2013). Monitoring Marine Invasive Species in Mediterranean Marine Protected Areas (MPAs).



- National Marine Fisheries Service, & U.S. Fish and Wildlife Service. (2021). Loggerhead sea turtle (*Caretta caretta*) North Indian Ocean DPS, Southwest Indian Ocean DPS, Southeast Indo-Pacific Ocean DPS, South Pacific DPS, South Atlantic Ocean DPS, Northeast Atlantic Ocean DPS, and Mediterranean Sea DPS 5-Year Review: Summar.
- Prakash, S., & Verma, A. K. (2022). Anthropogenic activities and biodiversity threats.
- Putland, R. L., & Mensinger, A. F. (2019). Acoustic deterrents to manage fish populations. *Reviews in Fish Biology and Fisheries*, 29(4), 789–807. <https://doi.org/10.1007/s11160-019-09583-x>
- Rey, A., Carney, K. J., Quinones, L. E., Lohan, K. M. P., Ruiz, G. M., Basurko, O. C., & Rodríguez-Ezpeleta, N. (2019). Environmental DNA metabarcoding: a promising tool for ballast water monitoring. *Environmental Science & Technology*.
- Romer, P. (2022). Paul Romer and the Suez and Panama Canals : 1–33.
- Tran, N., Chu, L., Chan, C. Y., Peart, J., Nasr-Allah, A. M., & Charo-Karisa, H. (2016). Prospects of fish supply-demand and its implications for food and nutrition security in Egypt Nhung (Vol. 4, Issue 1).
- Wang, Z., Saebi, M., Grey, E. K., Corbett, J. J., Chen, D., Yang, D., & Wan, Z. (2022). Ballast water-mediated species spread risk dynamics and policy implications to reduce the invasion risk to the Mediterranean Sea. *Marine Pollution Bulletin*, 174(August 2021), 113285. <https://doi.org/10.1016/j.marpolbul.2021.113285>
- Zielinski, D. P., McLaughlin, R., Castro-Santos, T., Paudel, B., Hrodey, P., & Muir, A. (2019). Alternative Sea Lamprey Barrier Technologies: History as a Control Tool. *Reviews in Fisheries Science and Aquaculture*, 27(4), 438–457. <https://doi.org/10.1080/23308249.2019.1625300>
- Treanor, H. B., Ray, A. M., Layhee, M., Watten, B. J., Gross, J. A., & H Webb, M. A. (2017). Using Carbon Dioxide in Fisheries and Aquatic Invasive Species Management (Vol. 42, Issue 12). [www.fisheries.org](http://www.fisheries.org)
- Uysal, I. (2019). ADDRESSING INVASIVE ALIEN SPECIES THREATS AT KEY MARINE Proceedings of the 1 st Mediterranean Symposium on the Non-Indigenous Species (Issue February).
- WÜST, G. (1935). Salinity and Water Movement in the Suez Canal. *The International Hydrographic Review*.